



# STEPP MFG

ASPHALT MAINTENANCE EQUIPMENT



## **OJK-H**

### **STEPP Oil Jacketed Kettle**



# **OPERATIONS/MAINTENANCE/PARTS MANUAL**

Diesel Burner Systems

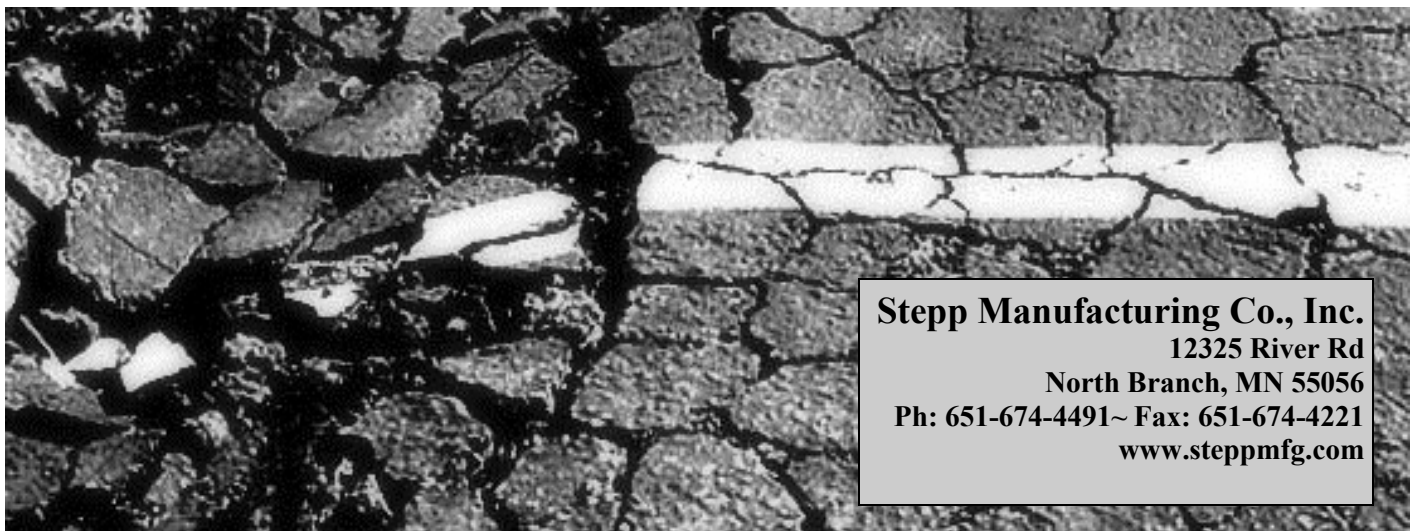

**Stepp Manufacturing Co., Inc.**  
12325 River Rd  
North Branch, MN 55056  
Ph: 651-674-4491~ Fax: 651-674-4221  
[www.steppmfg.com](http://www.steppmfg.com)

# *Warranty*

Stepp Manufacturing Company Inc. hereby warrants to the original purchaser that products manufactured by Stepp Mfg will be free from defects in material and workmanship for a period of 1 year from the date of purchase.

Stepp Mfg, at its discretion, will provide for the repair or replacement of any part found upon examination by Stepp Mfg to be defective, except as noted below. Such repair or replacement will be free of charge to the original purchaser for a period of 1 year from the date of purchase, except as noted below.

**No warranty is extended to cover:**

- Product pump wear or damage caused by foreign object.
- Routine maintenance, cleaning, and adjustments.
- Parts or components that have been altered, misused, improperly adjusted or maintained.
- Transportation to and from the place of warranty repair.
- Removal of material from equipment.

**The following items are covered solely by their manufactures warranty:**

- Engines
- Hydraulic components
- Burners
- Pumps
- Tires
- Other component parts

**The following items are covered by a pro rata warranty:**

- Hoses that carry heated materials.
- Heating Elements for hoses and wands.

**Disclaimer of further warranty:**

Stepp Mfg makes no warranty, expressed or implied, other than this warranty. The implied warranties of merchantability and fitness for particular purpose are hereby disclaimed. Repair or replacement of products or parts proving to be defective in material or workmanship shall be the exclusive remedy for breach of this warranty.

Stepp Mfg shall not be liable for incidental or consequential damages. Including but not limited to, damages for inconvenience, rental or purchase of replacement equipment, for loss of profits, loss of material, or other loss resulting from breach of this warranty.

Stepp Mfg reserves the right to incorporate any changes in design into its products without obligation to make such changes on products previously manufactured.

*Please see Warranty section for more details.*

*Stepp Manufacturing Co., Inc.*

12325 River Road

North Branch, MN 5506

P: 651-674-4491

F: 651-674-4221

www.steppmfg.com

# ***OJK– Oil Jacketed Kettle***

Thank you for selecting the *Stepp OJK* for your crack sealing operations. We are confident you will be satisfied with the *Stepp Oil Jacketed Kettle (OJK)*. *Stepp Manufacturing* is backed by over 65 years of experience in the design and manufacture of highway maintenance equipment. This experience along with our innovative design and unique features make the *Stepp OJK* the fastest and most efficient kettle available. Continued research and development, along with input from you, the user, help make this possible. This manual will make reference to components and systems that may not be installed on your equipment. Many of these are available as options and may be retrofitted to your machine. For more information contact Stepp Mfg.

To assure safe operation of this equipment, the operator must read and understand all operating procedures and safety notices contained in this manual. In addition, the operator *must* receive instruction on how to safely operate the *Stepp OJK*. Contact Stepp Manufacturing if any questions arise or if you desire training for additional staff members. Operating instructions, adjustments and periodic maintenance procedures are given so you ... the operator, can keep your unit working like new and expect many years of dependable service from it. Remember ... any machine, regardless of design or type, will perform only in relation to the way it is operated and the maintenance it receives. Read this manual carefully and observe all Warnings and Cautions. If you have any recommendations or comments, please send them attention to: **Stepp Manufacturing Co. Inc., 12325 River Road, North Branch MN. 55056-6225 or call 651-674-4491.**

When ordering parts or making any inquiry about the *Stepp OJK*, be sure to include the model number and serial number found on the data plate attached to the frame.



# **TABLE OF CONTENTS**

## **IMPORTANT NOTICE!**

This manual contains cautions and warnings that alert you to potential safety issues.

**WARNING** is used to inform you of conditions or operations that could cause serious injury or death.

**CAUTION** is used to inform you of conditions or operations that could cause damage to the equipment

**NOTE** is used to provide you with additional information that may be helpful or useful for a particular situation.

## **Table of Contents**

Introduction	3
Contents	5
Warnings, Cautions, Notes	5
Description	7
Operations	15
Maintenance	23
Troubleshooting	43
Replacement Parts	51
NHTSA Reporting Safety Defects	68
Warranty Guide	69
Watlow Programming	77
Schematics	87
Heat Transfer Oil MSDS	91
Hydraulic Oil MSDS	101
Tire Information/ Engine Manual	Inserts

This manual explains the basic operations, maintenance and use of the Stepp OJK, Oil Jacketed Kettle. The main objective of this equipment is to melt rubberized crack sealing and water proofing compound and apply them to road surfaces.



# DESCRIPTION

---

## DESCRIPTION

The *Stepp OJK* is designed to melt and apply rubberized crack sealing compounds to fill cracks in the roadway surface.

The *OJK* uses a tank surrounded by an oil jacket filled with heat transfer oil. The heat transfer oil is heated by a diesel fired burner and is circulated in the oil jacket by a pump. In addition to the oil jacket there is a coil surrounding the agitating auger in the tank. Heat transfer oil is pumped through this coil to facilitate heating of the asphalt material. The temperature of the product and the heat transfer oil is automatically maintained by electronic temperature controls.

The heated asphalt is applied to the crack by an electrically heated hose and wand. The heating element in the hose and wand keep the product at working temperature thus eliminating wand "freeze up". No clean-up or flushing of the wand & hose is required.

Power is supplied by a diesel engine. The engine drives a 24 volt alternator for the heated hose and wand. It also drives a hydraulic pump that powers the heat transfer oil circulation pump, product pump, and the agitating auger.

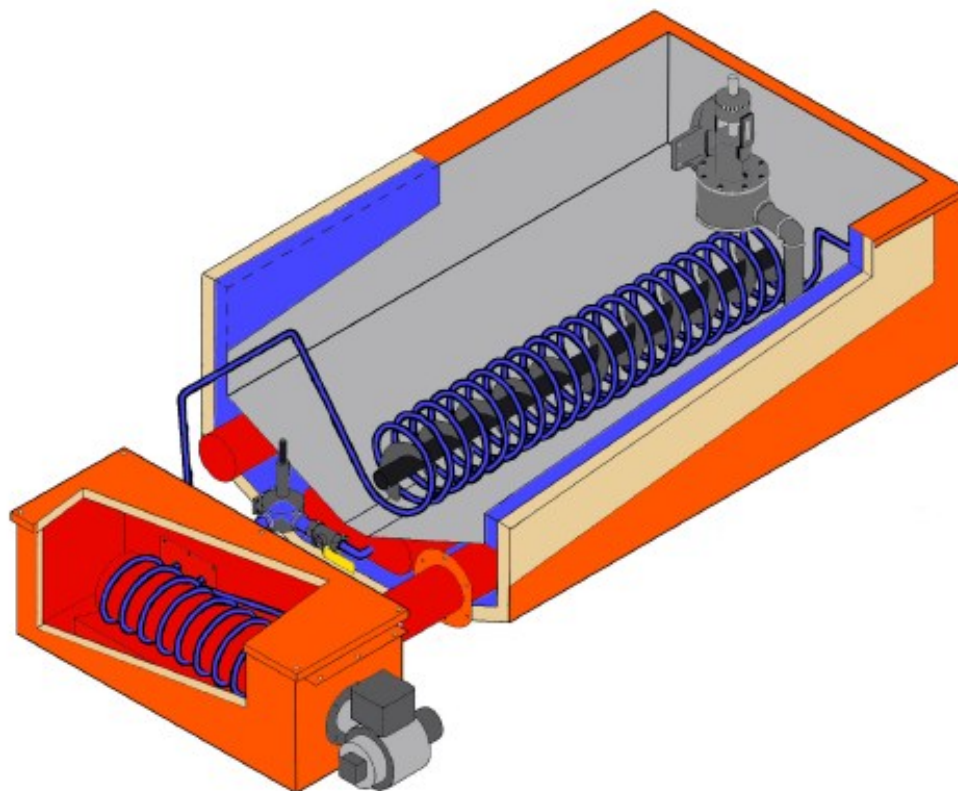

Heat from Burner



Heat Transfer Oil



Insulation



## Component Location

1. Product pump motor — Powers the pump that pumps the product from the tank to the wand.
2. Safety loading chute — Provides a "splash free" way of loading product into a "hot" tank.
3. Hood — Provides easy access to the inside of the tank for cleaning or "cold" loading.
4. Dip Stick/Fill Cap — Provides a way to check and fill the heat transfer oil tank.
5. Expansion tank — Provides room for the heat transfer oil to expand and allows the oil to cool. This creates a "cold seal" effect allowing safer operation at elevated oil temperatures.
6. Hydraulic pump — Provides hydraulic power to the heat transfer oil circulation pump, auger, and the product pump.
7. 24 volt alternator — Provides electrical power to the wand and hose heating elements.
8. Engine control panel — Provides a means of controlling engine functions.
9. Engine fuel filter — Provides clean fuel to engine.
10. Hydraulic filter — Removes contaminants from the hydraulic system.
11. Hydraulic reservoir — Provides a 15 gallon capacity for the hydraulic system.
12. Hydraulic suction screen — Prevents foreign objects from entering the hydraulic pump.
13. Fuel tank — Stores 30 gallons of diesel fuel to operate the burner and the engine.
14. Heat exchanger chamber — Exchanges heat from the burner to the heat transfer oil.
15. Oil pump drive motor — Drives the heat transfer oil circulation pump.
16. Wand & Hose — Provides a means of applying the product to the road surface.
17. Product pump control — Allows the operator to start, stop, or reverse the rotation and control the speed of the product pump.
18. Auger control — Allows the operator to start, stop, or reverse the rotation and control the speed of the agitating auger.

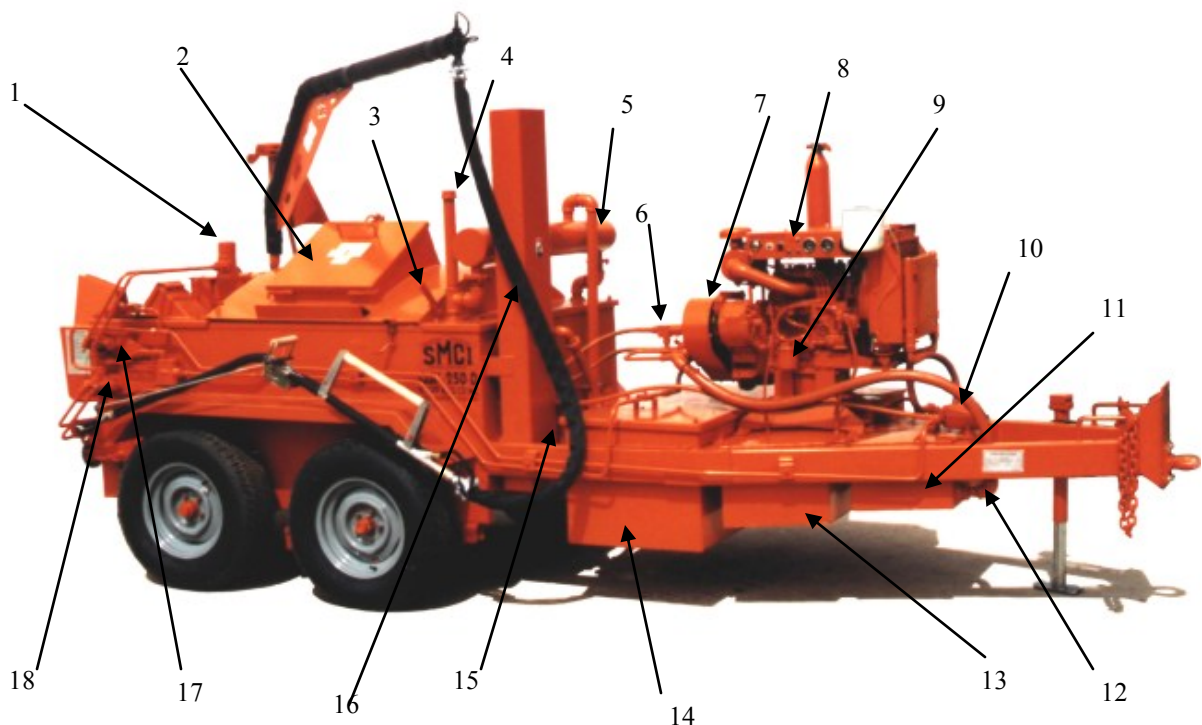

# DESCRIPTION

## Component Location

1. Wand Pressure Control (WPC) valve — Controls the amount of pressure being applied to the hose & wand when the Pump Saver System is not used. Also allows the operator to divert the flow of material back to tank for circulation, or to the wand for application to the road surface.
2. Thermometer — Indicates the temperature of the material as it is pumped from the tank.
3. Drive Motor — Hydraulic drive motor powers the product pump.
4. Circulating Flange — The wand is placed into this port allowing circulation through the wand and back to tank.
5. Wand Rest — Holds the wand in position when circulating through the wand back to tank.
6. Thermostats — Digital display thermostats control the temperature of the heat transfer oil and the product temperature.
7. Wand Heat Switch — Supplies power to the electric heated wand & hose.
8. Drive Motor — Hydraulic drive motor powers the agitating auger.
9. Electric over night heaters — Maintains heat transfer oil temperature of approximately 150 to 200°F.
10. Draw off cock — Provides a means of draining tank or filling dispensing equipment.
11. Thermal Well — Contains temperature sensor for product temperature.
12. Heat Transfer Oil Level Plug — Allows easy check of oil level only when unit is cold.
13. Boom Power Cable — Supplies power for the heating elements in the boom, hose, and wand.

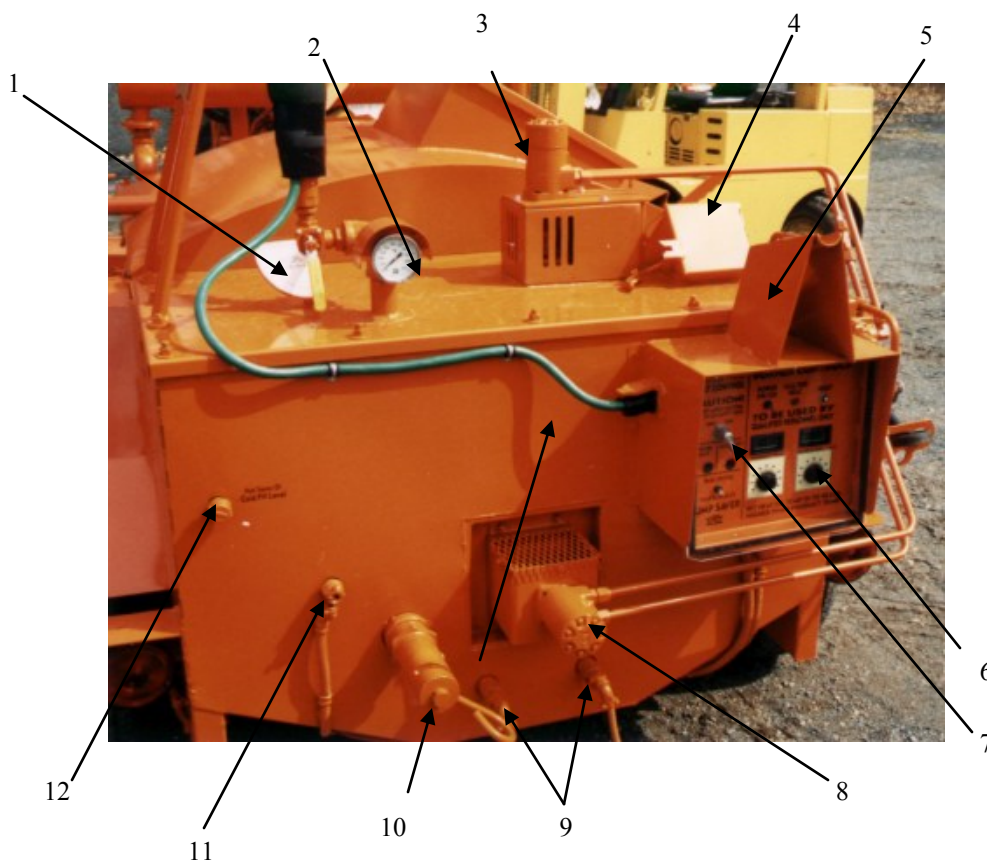

### ***Burner System***

The heating system is designed to burn diesel fuel and efficiently heat the transfer oil. The heating system is equipped with constant ignition (flameout protection) and automatic controls to monitor the temperature of the heat transfer oil and the product temperature. Heat transfer oil must be circulated through the heat exchanger when ever the burner is on. This prevents the heat exchanger from over heating and causing damage to the equipment. Operation of the engine is required during the heating cycle to supply hydraulic pressure to the heat transfer oil pump. The pump then circulates the heat transfer oil through the heat exchanger and the hot oil coil in the product tank.

Operation of the burner without the engine running and oil circulating will cause an overheat situation resulting in severe damage to the heat exchanger. Whenever the engine is shut down, the burner is also be shut down.

### ***Temperature Control***

The Stepp OJK is equipped with automatic temperature controls. Two thermostats are used to monitor the temperature of the heat transfer oil and the asphalt product. Both thermostats have the capability of shutting off the burner when their respective settings are reached. Continuous observation of the temperature is recommended. If temperatures exceed the thermostat settings, a possible problem with the thermostatic controls may exist. Shut the burner OFF and contact qualified service personnel.

### ***Agitator***

This unit is equipped with a hydraulically operated agitator with forward/reverse control. Operating the agitator during the heating cycle will decrease the amount of time and energy necessary to bring the product up to working temperature. The agitator should be turned on as soon as the material melts sufficiently to allow the agitator to rotate. Observe the drive motor for rotation as you engage the lever, if no rotation is observed, allow more heating time to melt the material. The agitator may be run in either direction and left on while applying crack filler. This will give superior performance through even heating of the product.

### ***Product Pump***

The *Stepp OJK* is equipped with a hydraulically operated product pump with "Pump & Reverse" control. In the "pump" position, the pump delivers product from the tank, through the hose, and to the wand for application to the road surface. In the "reverse" position the pump draws the product out of the product pump, plumbing, and WPC (wand pressure control) valve to prevent freeze-up when the unit is shut down. The product pump is mounted in the tank allowing it to heat to the proper temperature along with the product, thus it is not necessary to preheat the pump. The product pump should only be engaged when the product has reached a temperature that will allow the product to flow thorough the pump and plumbing.

## **DESCRIPTION**

### ***Wand Pressure Control Valve (WPC Valve)***

Operators must understand the proper operation of the WPC valve located on the top rear of the unit. The purpose of this valve is to direct the flow of product either back to the tank (during start-up to assist melting) or to the wand (during crack filling operations).

Because of the properties of rubberized asphalt, no automatic relief valve is installed in the system. Therefore, the operator must adjust the WPC valve to a position midway between the valve stops. This will allow product to flow to the wand and also back to the tank at the same time, preventing excessive pressure from building up in the hose and wand.

Positioning of the WPC valve towards "Re-circulate" will cause less flow and less pressure to the wand. Positioning of the WPC valve towards "Wand" will cause more flow and more pressure to the wand.

The WPC valve should never be positioned fully to the wand position unless the wand control valve located on the wand is fully open, or the optional "Pump Saver" feature is installed and in operation. Excess flow and pressure to the wand may cause damage to the hose and system resulting in personal injury.

Observing unusual flexing in the wand hose should alert the operator that excess pressure is being applied to the wand hose. Considering factors such as temperature of product, desired amount of flow and varied operating conditions will assist the operator in selecting the proper position of the WPC valve. The WPC valve must be left in the re-circulate position when the unit is shut down.

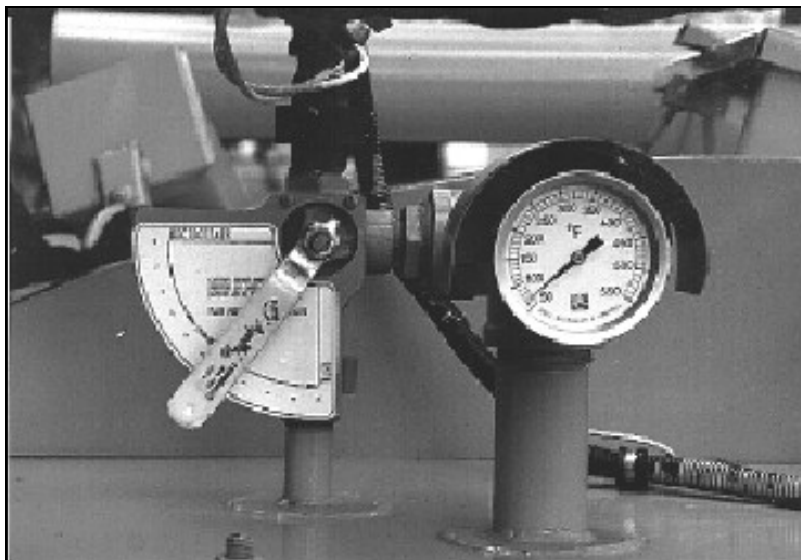

### ***Heated Hose & Wand***

The application wand and hose are equipped with an internal heating element. The element is powered by the 24 volt alternator run by the engine. This heating element prevents the product from "freezing" in the hose and wand.

The Electric Wand heat control should be turned on 20 to 30 minutes before trying to pump material through the hose and wand. This will allow time for the material to re-liquefy in the hose.

It is recommended that you circulate the product back to the tank through the wand circulating flange provided in the hood. This is to assure proper flow and temperature of the material going through the wand.

Depending upon the volume of the material going through the wand and the outside temperature, it may not be necessary to run the heated wand all the time. Once flow is established through the wand and circulating back to tank, it is recommended that the electric heating element be used only as required to maintain flow. This will help to extend the service life of the components. If the flow is not adequate to maintain temperature in the hose and wand, freeze up may occur. If this happens, simply turn the electric heating element on and allow time for the material to re-melt.

No clean up is required with the Electric Wand, just shut the machine off as the product can be re-melted by activating the Wand Heat Control. No additional flushing is required.

### ***Overnight Heater (optional)***

This feature will maintain the product from 150° to 200° F. thereby saving start up time. The system consists of 2 heating elements submerged in the heat transfer oil.

The heaters require 110V, 15 amp service. The extension cords used must be the outdoor heavy duty type, grounded, and each rated for 1500 watt service.

### ***Engine Controls***

The engine controls consist of a starter/glow plug switch, an un-loader switch to relieve the hydraulic pressure for starting purposes, a Murphy switch to stop the engine in case of low oil pressure or high coolant temperatures, and indicator lights for oil pressure, coolant temperature, alternator, and glow plugs. Optional equipment includes an hour meter and engine gauges.



# OPERATIONS

---



## Transporting

1. Shut off the burner and the engine.
2. Securely latch the loading chute and re-circulating flange.
3. Secure the wand and hose assembly in the hanger with rubber shock cords or rope.
4. Attach the unit to the towing vehicle being certain hitch is fully engaged, connect safety chains electrical connector, and break away switch (if equipped), retract the landing gear and secure in the up position.
5. Check the condition and operation of the lights, tires, brakes, hitch, and safety chains.

## Loading

It is very important that the operator know the operating temperature and flash point of the product being used. This information is available from the product manufacturer. Be sure the thermostat is set at the recommended temperature.

Prior to adding product to the tank, assure the compatibility of the product in the tank to that being loaded. If products are not compatible the tank must be thoroughly drained and cleaned before switching products.

### Loading When Cold

1. Release the hood latch.
2. Each side of the hood is equipped with a Lid Breaker to break open the hood if it is stuck.
3. Extend the telescopic handle, tighten the lock, and push down to open the hood.
4. Use the ring to secure in the open position.
5. Load product to the desired level.
6. Close and secure hood.

### Loading When Hot

1. Disengage agitator control.
2. Open loading chute and place block of product in chute, close loading chute and product will drop into tank. Open chute and repeat until product is at the desired level.
3. Close loading chute but **DO NOT** latch, this will allow for emergency venting in case of a "flash"
4. Engage agitator control when product is at proper temperature.





## Pre Start Checks

The burner system is equipped with a safety interlock that prevents the burner from igniting unless the engine is running.

This safety interlock must be tested each time before the engine is started. Follow the steps below prior to engine start.

1. With engine OFF, turn the burner power switch ON, the burner and blower motor should NOT operate. If the burner or blower motor runs there is a fault in the system, shut OFF burner switch immediately. Contact a qualified service technician and correct the problem before continuing.
2. Be sure the burner switch is in the OFF position.
3. Check the overall appearance of the unit inspecting for any obvious damage.
4. Check all fluid levels, the condition of the hot asphalt hose, and the 24 volt alternator belt. (refer to the daily maintenance schedule)

## Engine Starting

Be sure all pre-start checks are complete prior to starting engine.

1. Fill fuel tank.
2. Set the WPC valve to the "re-circulate" position.
3. Set wand heat control to OFF.
4. Set product pump control to neutral (center) position.
5. Set agitator control to neutral (center) position.
6. Turn key counter clockwise to the preheat position until the glow plug indicator light goes out.
7. Hold the un-loader button and the Murphy switch in, then turn the key to the start position, release key when engine starts, then release the Murphy switch.
8. Continue to hold the un-loader button for about 10 seconds to allow the engine to come up to speed, then release the un-loader button.
9. Check to see that the heat transfer oil pump is rotating, if not, investigate problem before proceeding to Heating Operations.



## Burner & Pump Operations

1. Start engine (see engine operations).
2. Open burner exhaust rain cap.
3. Unlatch loading chute, this will allow for emergency venting in case of a "flash".
4. Set heating oil thermostat 25 to 50° F above the asphalt product manufacturers recommended temperature.
5. Set product thermostat to the product manufacturers recommended temperature.
6. Turn ON burner power switch and the burner will ignite.
7. When product begins to melt, slowly engage agitator and observe drive motor for rotation, if it does not rotate, allow additional heating time before engaging.
8. If equipped with "Pump Saver" option, set pump saver switch to "re-circulate" position.
9. As the product reaches application temperature, place the WPC valve in the "re-circulate" position and slowly engage product pump hydraulic valve to the "pump" position and observe pump motor for rotation, if no rotation is observed, allow additional heating time. (This will circulate the product with-in the pump and tank.)
10. Place wand into the re-circulating flange and fully open the wand flow control valve located on the wand handle.
11. Set the Electric Wand Heat Control to the ON position and allow 20 to 30 minutes for the elements to heat.
12. Continue to re-circulate the product until the recommended temperature is reached as indicated on the thermometer next to the WPC valve.
13. Slowly move the WPC valve towards the "wand" position to allow the product to flow through the wand and back to the tank. If no product flows out the wand, allow additional time for the electric heating elements to melt the product in the hose and wand.
14. When the product is flowing freely and temperatures are stabilized, the product is ready to apply to the road surface. Proceed to "Application Operations".



### Standard Application Operations

**Note: If Pump Saver option is installed, refer to Pump Saver Application instructions at bottom of page.**

1. Position the WPC valve midway between the wand and re-circulate position.
2. Close the wand flow control valve (located on the wand handle) and remove wand from the re-circulating flange.
3. Set product pump hydraulic control valve to "pump" position, then open the wand flow control valve to apply product to the road surface.
4. Adjust the WPC valve and the pump hydraulic control valve as necessary being careful not to over pressurize the wand and hose assembly.
5. Monitor the level in the tank and add product as necessary.

### Application Operations with Optional "Pump Saver"

1. Set Pump Saver switch to "Wand Control" position.
2. Position the WPC valve fully to "wand" position.
3. Close the wand flow control valve (located on the wand handle) and remove wand from the re-circulating flange.
4. Set product pump hydraulic control to "pump" position, then open the wand flow control valve to apply product to the road surface.
5. Adjust the product pump hydraulic control valve as necessary for the desired flow.
6. Monitor the level in the tank and add product as necessary.

**CAUTION**

*Do not engage wand heat unless there is product in the hose.*

**CAUTION**

Positioning of the WPC valve all the way to the "wand" position may cause excess pressure in the wand which may cause damage to the wand hose or system.

The WPC valve should not be positioned fully to the "wand" position unless the wand flow control valve located on the wand is open and product is flowing freely. Or the optional pump saver is in operation.

Observing unusual flexing in the wand hose should signal the operator that excess pressure is being applied to the wand hose and the WPC valve should be adjusted accordingly.

## Standard Shut Down Procedures

*Note: If Pump Saver option is installed, refer to shut down procedures at bottom of page.*

1. Turn OFF the wand heat control switch.
2. Move the WPC valve to the "re-circulate" position.
3. Move the product pump hydraulic control valve to the "reverse" position for 2 minutes, then return lever to the neutral position. This will draw the product out of the pump, plumbing, and WPC valve.
4. Turn both thermostats to their lowest setting.
5. Turn OFF the burner power switch.
6. Place the agitator control lever in the neutral position.
7. Close the rain cap on the exhaust stack.
8. Securely latch all covers

## Shut Down Procedure with Optional "Pump Saver"

1. Turn OFF the wand heat control switch.
2. Move the product pump hydraulic control valve to the neutral (center) position.
3. Move the WPC valve to the "re-circulate" position.
4. Set the Pump Saver switch to the "Pump Re-circulate" position.
5. Move the product pump hydraulic control valve to the "reverse" position for 2 minutes, then return lever to the neutral position. This will draw the product out of the pump, plumbing, and WPC valve.
6. Turn both thermostats to their lowest setting.
7. Turn OFF the burner power switch.
8. Place the agitator control lever in the neutral position.
9. Turn key to OFF position to shut down the engine.
10. Close the rain cap on the exhaust stack.
11. Securely latch all covers.

### **CAUTION**

The Stepp OJK requires special shut down procedures that must be followed to maximize safety and equipment performance.

These procedures will assure that the hose and wand always have product in them to avoid an over heated element. (Do Not suck the product back out of the wand and hose assembly)

No hose cleanup is necessary as the product in the hose is re-melted at the next start-up with the wand & hose heating element.

### **CAUTION**

Do not reverse the pump with the WPC valve in the "wand" position as this would suck the product out of the wand and hose assembly. The hose and wand must contain product to absorb the heat from the heating elements to avoid equipment damage. Only reverse the pump when the WPC valve is in the "recirculate" position. No hose cleanup is necessary with this system.

## Helpful Hints

1. It is recommended that the product level be drawn down to  $\frac{1}{4}$  capacity or less prior to shut down if the machine is not going to be used for 2 or more days. This will decrease the start-up time the next time the machine is used. However, if the equipment will be used the next day leave the unit  $\frac{1}{2}$  full or more, then plug in the optional overnight heaters (if available). This will help retain heat for a faster start-up the following day.
2. Over night heating elements normally should not be used for more than 48 hours. Check your product manufacturers specifications for recommended "pot" life.
3. Do not heat or reheat any product for a length of time more than that recommended by the product manufacture. The result of excessive heating time is the material hardens and may be difficult or impossible to remove from the machine.
4. The flow control valve at the end of the wand is not heated by the heating element. Although heat transfer from the wand will normally be enough, by inserting the wand into the re-circulating flange, additional heat from the kettle will aid in heating the valve.
5. If the engine quits for any reason, move the WPC valve to the re-circulate position then attempt to resolve the problem and restart the engine as soon as possible. The proper shut down procedures must be followed before the product hardens in the plumbing between the WPC valve and the top of the kettle. If the product hardens between the WPC valve and the top of the kettle, use heat to re-liquefy the product to reestablish flow.



# MAINTENANCE

---



# OJK MAINTENANCE SCHEDULE

ITEM	OPERATION TO PERFORM	HOURS	AS NEEDED	DAILY	EVERY 3MO	EVERY 12 MO	EVERY 24MO
<b>ENGINE</b>	Refer to the engine manufacturers manual insert						
OIL	Check engine oil level, add oil as needed			<b>X</b>			
OIL	Change engine oil and filter.	<b>100</b>					
COOLANT	Check coolant level.			<b>X</b>			
COOLANT	Flush cooling system and replace coolant						<b>X</b>
RADIATOR	Clean radiator fins of dirt and dust with garden hose.		<b>X</b>				
AIR FILTER	Clean air filter		<b>X</b>				
AIR FILTER	Replace air filter	<b>100</b>				<b>X</b>	
FUEL FILTER	Replace fuel filter					<b>X</b>	
FAN BELT	Check condition and tension			<b>X</b>			
<b>HYDRAULICS</b>							
HYD. OIL	Check hydraulic oil level, add oil as necessary			<b>X</b>			
HYD. OIL	Change hydraulic oil.						<b>X</b>
FILTER	Change hydraulic filter.	<b>200</b>				<b>X</b>	
STRAINER	Clean strainer screen					<b>X</b>	
<b>DRIVE LINE</b>							
ALT. BELTS	Check condition and tension of 24v alternator belts			<b>X</b>			
STUB SHAFT	Check stub shaft on engine for wear, looseness, and damage					<b>X</b>	
COUPLING	Check drive line coupling for proper alignment and excess wear.					<b>X</b>	



# OJK MAINTENANCE SCHEDULE

ITEM	OPERATION TO PERFORM	HOURS	AS NEEDED	DAILY	EVERY 3MO	EVERY 12 MO	EVERY 24MO
<b>BURNER</b>							
ELECTRODES	Check electrodes for wear and proper adjustment.					X	
BRUSHES	Check brushes for excess wear	300			X		
NOZZLE	Replace fuel nozzle with same size and style					X	
FILTER	Replace burner fuel filter	400				X	
F-HEAD	Check condition of F-head on burner					X	
<b>CONTROLS</b>							
THERMOSTAT	Check that index marks are aligned on knobs for proper calibration			X			
<b>HOT PUMP</b>							
CLEARANCE	Check and adjust end clearances of heat transfer oil pump.						X
PACKING	Adjust shaft seal packing of heat transfer oil pump.		X				
COUPLING	Check pump to hyd. Motor coupling for proper alignment and excess wear.					X	
<b>PRODUCT PUMP</b>							
CLEARANCE	Adjust end clearances of product pump.		X				
PACKING	Adjust shaft seal packing of pump.		X				
COUPLING	Check pump to hyd. Motor coupling for proper alignment and excess wear.					X	
<b>HEAT TRANSFER OIL</b>							
OIL	Check heat transfer oil level.			X			
OIL	Change heat transfer oil.						X

# OJK MAINTENANCE SCHEDULE

ITEM	OPERATION TO PERFORM	HOURS	AS NEEDED	DAILY	EVERY 3MO	EVERY 12 MO	EVERY 24MO
<b>HEATED HOSE</b>							
JACKET	Check condition of hose safety jacket. Replace if damaged.			<b>X</b>			
HOSE	Check condition of hose. Replace if damaged.				<b>X</b>		
HOSE	Replace Hose					<b>X</b>	
CONNECTION	Check condition of tightness of hose and wire connections.			<b>X</b>			
BOOM	Check boom, boom support, and lock pin for cracks or damage.				<b>X</b>		
<b>PRODUCT TANK</b>							
TANK	Clean and inspect interior for leaks or damage.					<b>X</b>	
PACKING	Adjust packing seal on auger shaft.		<b>X</b>				
COUPLING	Check auger to hyd. Motor coupling for proper alignment and excess wear.					<b>X</b>	
BEARINGS	Check auger bearing mounts for looseness and excessive wear.					<b>X</b>	
HEAT COIL	Check heating coil for damage or leaks					<b>X</b>	
HEAT COIL	Check for leaks and tighten fittings on each end of the heating coil.					<b>X</b>	

# OJK MAINTENANCE SCHEDULE

ITEM	OPERATION TO PERFORM	HOURS	AS NEEDED	DAILY	EVERY 3MO	EVERY 12 MO	EVERY 24MO
CHASIS							
TIRES	Check tire condition and pressure			X			
BRAKES	Check brake operation.			X			
BRAKES	Inspect and adjust brake shoes, drums, and components.				X		
LUG NUTS	Check lug nuts for proper torque.				X		
BEARINGS	Inspect wheel bearings and repack with grease.					X	
SUSPENSION	Inspect all suspension components for wear, breaks, or damage				X		
LIGHTS	Check that all lights function properly.			X			
FRAME	Inspect frame for cracks or damage.					X	
HITCH	Inspect hitch for wear, damage, and proper adjustment.			X			

# OJK MAINTENANCE RECORD

DATE	MAINTENANCE PERFORMED	HOUR METER	SERVICED BY

***All maintenance items must be performed according to the maintenance schedules and documented for warranty coverage to be effective.***

**OJK MAINTENANCE RECORD**

<b>DATE</b>	<b>MAINTENANCE PERFORMED</b>	<b>HOUR METER</b>	<b>SERVICED BY</b>

***All maintenance items must be performed according to the maintenance schedules and documented for warranty coverage to be effective.***



# **Engine Maintenance**

## **Oil & Filter Change**

1. Run engine until operating temperature is reached, then shut OFF engine.
2. Place drain pan under oil drain hose.
3. Open oil drain valve and drain oil from the engine.
4. Close the oil drain valve.
5. Place drain pan under engine oil filter and remove filter.
6. Coat gasket of new oil filter with engine oil and install, hand tighten only.
7. Add 5 quarts SAE 10 W 40 oil.
8. Run engine and check for leaks.
9. Return used oil to a recycling center.

## **Air Cleaner Service**

1. Remove wing nut in center of air cleaner.
2. Remove filter.
3. Clean element following instructions on air cleaner housing. Element may be cleaned up to 6 times before replacement.
4. Reinstall element in housing and tighten wing nut.

## **Fuel Filter Change**

1. Position drain pan under fuel filter.
2. Remove fuel filter.
3. Fill new filter with clean diesel fuel.
4. Lubricate gasket with fuel and install filter, hand tighten.
5. Loosen the air vent plug on the injection pump where the fuel line is attached.
6. Pump the lever on the fuel pump until no air bubbles are present, tighten air vent plug.

## **Cooling System Service**

1. Allow engine to cool to ambient temperature.
2. Open radiator petcock and drain coolant into a suitable container.
3. Open petcock on left side of engine block and drain into a suitable container.
4. Open radiator cap and remove lower radiator hose.
5. Flush clean water through radiator until the water comes out clear.
6. Remove the thermostat then flush clean water through the engine block until the water comes out clear.
7. Install new thermostat and gasket.
8. Install radiator hose and close all petcocks.
9. Refill system with fresh anti freeze in a 50/50 mix.
10. Run engine and check for leaks, then recheck coolant level after engine has cooled.

# Hydraulic System Maintenance

## **Filter Change**

1. Position drain pan under filter.
2. Remove oil filter.
3. Lubricate gasket of new filter with hydraulic oil.
4. Install new filter, hand tighten.
5. Start unit and check for leaks.
6. Shut down unit then check hydraulic oil level.

## **Hydraulic Oil Change**

1. Position drain pan under the hydraulic reservoir. (reservoir capacity exceeds 15 gallons, be sure drain pans have adequate capacity)
2. Remove drain plug from bottom of reservoir and drain oil.
3. Return used oil to a recycling center.
4. Replace drain plug using pipe sealer on threads.
5. Fill reservoir with hydraulic oil to about 3 to 4 inches from the top of the tank. (approx 15 gal.)

## **Strainer Screen Service**

1. Position drain pan under the hydraulic reservoir. (reservoir capacity exceeds 15 gallons, be sure drain pans have adequate capacity)
2. Remove drain plug from bottom of reservoir to drain oil.
3. Replace drain plug using pipe sealer on threads.
4. Remove hose clamps and 1¼" suction hose from nipple on hydraulic reservoir tank.
5. Unscrew king nipple from street-el.
6. Unscrew strainer from tank and clean in solvent.
7. Apply pipe sealer to threads and reinstall strainer and king nipple.
8. Attach 1¼" suction hose to king nipple and tighten clamps.
9. Refill hydraulic reservoir with hydraulic oil.
10. Check for leaks.



# Heat Transfer Oil Maintenance

## Heat Transfer Oil Level Check

1. Remove oil fill cap on top of expansion tank.
2. Cold oil level should be at the lower notch and the hot level at the upper notch in the dipstick. The cold level may also be checked by removing the cold oil level plug located to the lower left of the control panel on the rear of the machine.
3. Allow unit to cool, then add heat transfer oil as necessary, use Heat Transfer Oil with a minimum flash point of 550° F. C.O.C.
4. Replace oil fill cap.

## Heat Transfer Oil Change

1. Allow unit to cool to ambient temperature.
2. Approx. oil capacities are 20 gal (OJK75), and 25 gal (OJK125), have suitable containers ready to contain oil.
3. Remove the drain plug from lower rear of unit and drain oil into drain pan(s). Note; If optional overnight heater is installed, remove to allow the oil to drain.
4. Replace drain plug and return oil to a recycling center.
5. Remove oil fill cap and add oil to the cold fill mark on the dipstick, or until oil flows from the cold oil level plug on the rear of the machine. Use Heat Transfer Oil with a minimum flash point of 550° F. C.O.C.
6. Heat unit to normal operating temperature and verify oil is half full in the expansion tank.

## Packing Adjustment, Hot Oil Pump

*Note: The packing gland requires a small amount of leakage (one drop every couple minutes) for lubrication, if leakage becomes excessive, adjust only enough to stop the excessive leakage.*

1. Stop Engine.
2. Tighten 2 nuts on adjusting plate equally to control leakage. (Do not over tighten)
3. Start machine and check amount of leakage.
4. Readjust as necessary.

### **Important**

#### **WARNING**

The proper heat transfer oil level is critical to the safe operation of this equipment. The most accurate way to check the oil level is when the unit is at operating temperature, however, extreme caution must be used since the dipstick and the oil are very hot and will cause severe burns. Wear leather gloves, eye and face protection, and other appropriate safety gear when checking the oil level.

It is important that the oil level (when hot) be approximately half full in the expansion tank. Allow the unit to cool before adding oil. Do not allow any water or moisture to be introduced into the system.

**Note:** The heat transfer oil will expand approximately 10 to 15% when heated from 60°F to 400°F. Make allowance for this when adding oil to a cold system.

**Note:** The unit is shipped with LUBE-TECH Ace Heat Transfer Oil 460. Use this or an equivalent heat transfer oil.

## **Burner Maintenance**

### **Fuel Filter Replacement (burner)**

1. Close fuel shut off valve located at the fuel tank.
2. Remove the nut securing the canister to the fuel filter body.
3. Remove the canister and the filter element.
4. Replace the element with a new one.
5. Reinstall the canister and turn on the fuel valve.
6. Attach a clear hose to the fuel pump bleeder screw on the burner and direct the hose into a suitable container.
7. Start engine, set thermostats, then turn on the burner power switch. This will allow the fuel pump in the burner to run so the fuel system can be bled of air.
8. Loosen the bleeder screw and observe the flow of fuel through the clear hose, when all air is purged from the system close the bleeder screw.
9. Check entire fuel system for leaks.
10. Set the thermostats to the desired level and the burner will ignite.

### **Brush Inspection (Every 300 hours)**

1. Using a screwdriver, remove 2 brush holders located on the exterior of the motor housing and remove the brushes.
2. Replace brushes if less than 1/4 inch in length.

## **Combustion Chamber Inspection**

1. Allow unit to cool to ambient temperature.
2. Remove 6 nuts and washers securing combustion chamber cover and remove cover.
3. Inspect heat transfer tubes for any signs of leaks, cracks, or deformation.
4. Using a pick or similar tool, probe the heat transfer tubes for any sign of flaking, scaling, distortion, thin metal or other deterioration.
5. Inspect insulation support clips for damage.
6. Inspect end diffuser plate for cracking or warping.
7. Inspect liner for cracks, excessive deformation, or other signs of deterioration.
8. Inspect entire combustion chamber area for any other signs of leakage, damage or fatigue.
9. Reinstall cover if no damage is found.
10. If any damage is found it must be repaired before returning the unit to service. Contact Stepp Mfg (651) 674-4491 for replacement parts.

## **Combustion Chamber Liner and Heat transfer tube replacement.**

1. Allow unit to cool to ambient temperature.
2. Remove 6 nuts and washers securing combustion chamber cover and remove cover.
3. Remove the bolt that locks the hot-oil valve in the open position and close the valve.
4. Remove the heat transfer oil hose connections at the inlet and outlet of the heat exchanger. Cap the inlet and outlet ports to prevent oil spillage in the combustion chamber when the tubes are removed.
5. Remove the six bolts securing the heat transfer tubes to the combustion chamber housing.
6. Remove Fuel lines and electrical connections from burner.
7. Remove four bolts from burner flange and remove burner.
8. Lift heat transfer tubes and liner from combustion chamber housing.
9. Replace any insulation that is damaged or soaked with fuel or oil. Be sure to replace only with the same type insulation, contact Stepp Mfg for the proper insulation.

## Liner and Heat transfer tube replacement (continued)

10. Install liner into heat transfer tubes.
11. Install liner & tube assembly into the combustion chamber housing.
12. Install the six bolts securing the heat transfer tubes to the combustion chamber housing.
13. Slide the liner to the end of the housing where the burner is mounted, then install the retaining clip over a tube and weld to the liner. Note: Do not weld on the heat transfer tubes.
14. Install the burner on the flange and install the four bolts.
15. Reconnect the fuel lines and electrical connections to the burner.
16. Reconnect the heat transfer oil hose connections at the inlet and outlet of the heat exchanger.
17. Open the hot oil valve and lock (bolt) in the open position. *Note: Operation of the burner with the valve closed will result in severe damage to the heat exchanger assembly.*
18. Reinstall the combustion chamber cover with six nuts and washers.
19. Check the heat transfer oil level and add as necessary.
20. Start the engine and allow to run for ten (10) minutes prior to igniting the burner. This will purge any air out of the heat transfer tubes before subjecting them to the heat from the burner.

## Hot Asphalt Hose Replacement

**CAUTION** Do not remove hose without first removing the heating element or damage to heating element will result.

### Hose Removal:

1. Remove heating element from hose. (refer to heating element removal procedures)
2. Disconnect all electrical connections from hose.
3. Separate the hose from the wand at the quick coupling.
4. Remove the quick coupling from the hose and save for reuse on the new hose.
5. Unscrew the hose from the *cross* fitting at the end of the boom assembly.

### Hose Installation:

1. Screw the hose fitting into the *cross* fitting at the end of the boom assembly and tighten securely.
2. Screw the quick coupling to the other end of the hose and tighten securely.
3. Reconnect all electrical connections to hose.
4. Re-install heating element into hose, but do not reconnect electrical connector at this time. (note: the heating element will protrude about 10" from the end of the hose)
5. Gently heat the end of the wand with a propane torch. This will soften the material in the wand for easy insertion of the protruding hose heating element. (see next step)
6. Connect the hose to the wand at the quick coupling. Use gentle pressure to insert the protruding hose heating element into the wand.

**CAUTION** Do not apply power to the hose heating element in an empty hose or damage to the hose will result.

7. Bring material in tank up to operating temperature. (refer to operating instructions)
8. Verify hose heating element is disconnected.
9. Activate wand and boom heat for 20 minutes.
10. Pump material through wand until flowing freely. (refer to operating instructions)
11. Stop pump. Connect hose heating element connector. The hose is now full of material and the unit can be returned to service.

## Hose Heating Element Replacement (Functioning Element)

### Hose Heating Element Removal:

These instructions assume the heating element is functioning properly. If the heating element does not function, refer to the instructions on the following pages.

Note: If the hose is damaged, skip steps 1 through 3, activate wand heat for 15 minutes, then begin at step 4.

1. Start the engine and the burner and allow the product to reach operating temperature. Activate wand heat switch. Begin circulation of material through the wand into the re-circulating flange when temperatures permit. When product is circulating freely proceed to step 2.
2. Turn OFF the electric wand heat. Then with wand valve open, and the wand pressure control valve in the "wand" position, reverse the pump for 2 minutes to clear the hose, wand, and boom of material.
3. Shut OFF the burner and the engine.
4. Disconnect the hose heating element connector at the end of the boom.

**Note:** *The following steps must be accomplished with all components warm.*

5. Remove the compression fitting that holds the hose heating element at the top of the "cross" fitting on the end of the boom.

**WARNING** *The heating element will be HOT, wear protective clothing, leather welding gloves, and safety gear.*

**CAUTION** *Do not pull on the wires to remove the heating element or damage to the element may result.*

6. Gently pull the heating element from the "cross" fitting and the hose.

## **Hose Heating Element Installation:**

1. Remove wand from hose at quick coupling.
2. Lay the hose out as straight as possible.
3. Install new compression fitting into *cross* fitting.

**If hose does *not* contain material proceed with step 4.**

**If hose *contains* material, replace step 4 with steps A & B listed below.**

4. Insert heating element into compression fitting and hose. (About 10" of the heating element will protrude out the other end of the hose) Tighten compression fitting.
5. Insert protruding element into wand and reattach wand to hose at quick coupling. (gently heat wand with propane torch to ease installation if needed)
6. Reconnect all electrical connections.

***CAUTION*** *Do not apply power the hose heating element in an empty hose or damage to the hose will result.*

7. Bring material in tank up to operating temperature. (refer to operating instructions) and activate wand heat.
8. Pump material through wand until flowing freely. (refer to operating instructions) The hose is now full of material and the unit can be returned to service.

## **Steps A & B**

A. Connect one lead of the heating element to the large terminal of the 24V alternator, and the other lead to a good chassis ground. Use 10 gage (minimum) jumper wires.

**WARNING** The heating element will be HOT, wear protective clothing, leather welding gloves, and safety gear.

B. Start the engine, as the heating element heats, insert it into the hose. Start and stop the engine, or disconnect the jumper wires, as needed to regulate the heat of the element. Use only enough heat to soften the material and allow the element to be pushed into the hose. (About 10" of the heating element will protrude out the other end of the hose) Tighten compression fitting.

Proceed to step 5 above.

## Hose Heating Element Replacement

### (Non-Functioning Element)

#### Hose Heating Element Removal and Installation:

These instructions assume the heating element is damaged and *not* functioning. If the heating element functions properly, refer to the instructions on the preceding page. The element may be damaged during removal rendering it useless.

A functioning hose heating element is slid into the hose along side the non-functioning element. As the material in the hose is heated with the new element, the old element can be pulled from the hose.

1. Remove wand from hose at quick coupling. About 10" of the hose heating element protrudes out the hose and into the wand. Gently heat wand with propane torch to ease separation if needed.
2. Disconnect the hose heating element connector at the end of the boom.
3. Remove the compression fitting nut that holds the hose heating element at the top of the "cross" fitting on the end of the boom. Then remove the complete compression fitting.
4. Pull the element out and to the side far enough to allow a new element to be slid in along side the old element.
5. Slide a new compression fitting assembly onto the new heating element, but do not tighten.
6. Connect one lead of the new element to the large terminal of the 24V alternator, and the other lead to a good chassis ground. Use 10 gage (minimum) jumper wires.

***WARNING*** *The heating element will be HOT, wear protective clothing, leather welding gloves, and safety gear.*

7. Start the engine, as the heating element heats, insert it into the hose along side the old element. Start and stop the engine, or disconnect the jumper wires, as needed to regulate the heat of the element. Use only enough heat to soften the material and allow the element to be pushed into the hose.
8. Pull the old heating element from the "cross" fitting and the hose.
9. Secure new heating element in compression fitting, then reconnect electrical connector.
10. Insert protruding hose element into wand and reattach wand to hose at quick coupling. (gently heat wand with propane torch to ease installation if needed)



## Wand & Boom Heating Element Replacement

### Wand or Boom Heating Element Removal and Installation:

These instructions assume the heating element is damaged and *not* functioning. The element may be damaged during removal rendering it useless.

A functioning heating element is slid into the wand or boom along side the non-functioning element. As the material is heated with the new element, the old element can be pulled from the wand or boom.

1. Remove wand from hose at quick coupling. About 10" of the hose heating element protrudes out the hose and into the wand. Gently heat wand with propane torch to ease separation if needed.
2. Remove the compression fitting nut that holds the heating element in the wand or boom. Then remove the complete compression fitting.
3. Pull the element out and to the side far enough to allow a new element to be slid in along side the old element.
4. Slide a new compression fitting assembly onto the new heating element, but do not tighten.
5. Connect one lead of the new element to the large terminal of the 24V alternator, and the other lead to a good chassis ground. Use 10 gage (minimum) jumper wires.

***WARNING*** *The heating element will be HOT, wear protective clothing, leather welding gloves, and safety gear.*

6. Start the engine, as the heating element heats, insert it along side the old element. Start and stop the engine, or disconnect the jumper wires, as needed to regulate the heat of the element. Use only enough heat to soften the material and allow the element to be pushed into the wand or boom.
7. Pull the old heating element from the wand or boom.
8. Secure new heating element in compression fitting, then reconnect electrical connector.

An alternate method is to remove all insulation from the wand or boom. Then heat as needed with a torch to soften the material allowing removal and installation of the heating element.



# **TROUBLE SHOOTING**

---

## **HYDRAULIC SYSTEM**

	<i><b>POSSIBLE CAUSE</b></i>	<i><b>Items to Check /Service</b></i>
<b>LACK OF PERFORMANCE</b>	Plugged Strainer Screen	Service strainer screen
	Hydraulic Filter Plugged	Replace hydraulic oil filter
	Collapsed Suction Hose	Replace suction hose and service strainer screen
	Air Leak in Suction Hose	Replace hose.
	Low Fluid Level	Fill Reservoir to proper level.
	Over Heated Hydraulic Fluid	Clean oil cooler fins with pressurized water.
	Worn Pump or Hydraulic Motor	Adjust, rebuild, or replace as necessary.
	Crushed Hydraulic Lines	Replace line.
	“Brand” valve relief out of adjustment	Adjust relief on “Brand” valves to 1000 lbs.
<b>HYDRAULIC MOTORS DO NOT TURN OR TURN SLOWLY</b>	Product in Tank not Melted	Allow for more time for product to melt
	Foreign Material Jamming Agitator	Remove foreign material from agitator.
	Foreign Material Jamming Product Pump	Remove foreign material from product pump.
	Also see “Lack of Performance”	
<b>UNUSUAL NOISES</b>	Low Hydraulic Fluid	Fill reservoir to proper level.
	Air Leak in Suction Hose	Replace Hose
	Damaged Pump or Hydraulic Motors	Repair or replace as necessary
<b>EXCESSIVE OIL LEAKS FROM PUMP OR HYDRAULIC MOTOR SHAFT</b>	Bad Shaft or Shaft Seal	Replace as necessary.

**PRODUCT DELIVERY**

	<i><b>POSSIBLE CAUSE</b></i>	<i><b>Items to Check /Service</b></i>
<b>PRODUCT PUMP DOES NOT TURN</b>	Product in Tank not Melted	Allow more time for product to melt.
	Foreign Material Jamming Product Pump	Remove foreign material from product pump
	Pump Motor not Functioning	Refer to “Hydraulic System” Trouble Shooting
<b>LACK OF FLOW FROM WAND</b>	Product Temperature too Cold.	Heat product to manufacturers recommended temperature.
	Product “Froze” in Wand & Hose	Allow additional time for heating element to melt product in hose.
	Non-functioning Heat Element in Hose	Refer to “Electric Wand & Hose” Trouble Shooting
	WPC Valve not Positioned Correctly	Refer to operating instructions for WPC Valve position.
	WPC Valve and External Plumbing “Froze”	Heat to re-melt product
	Worn Product Pump	Adjust or repair product pump as necessary.

# TROUBLE SHOOTING

# PRODUCT PUMP

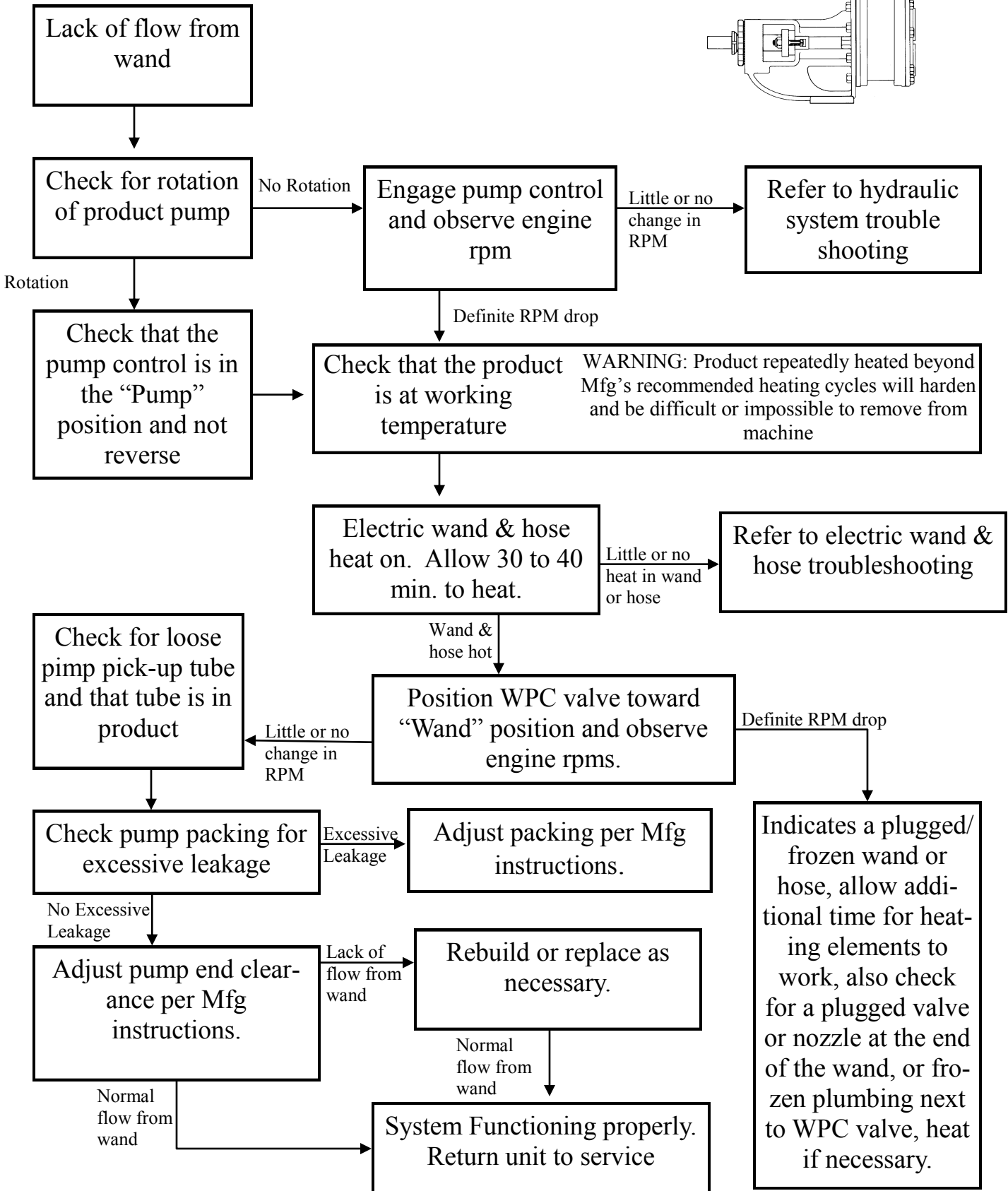
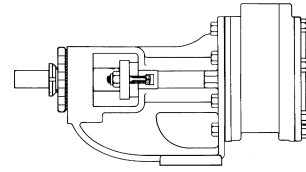

## Electric Wand & Hose Troubleshooting

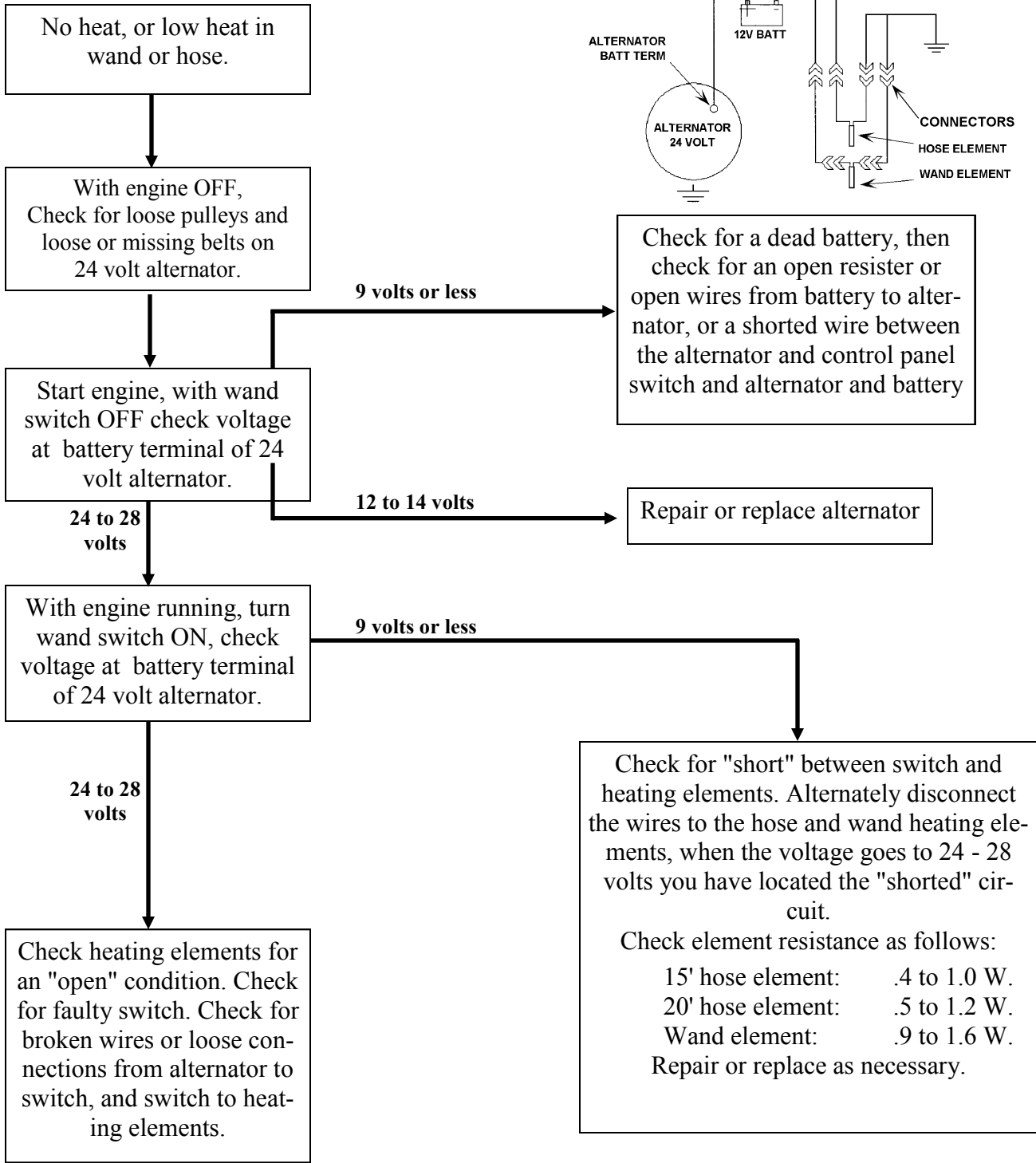
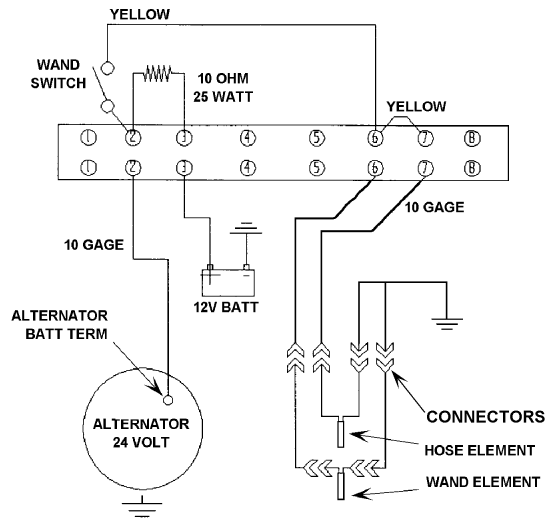

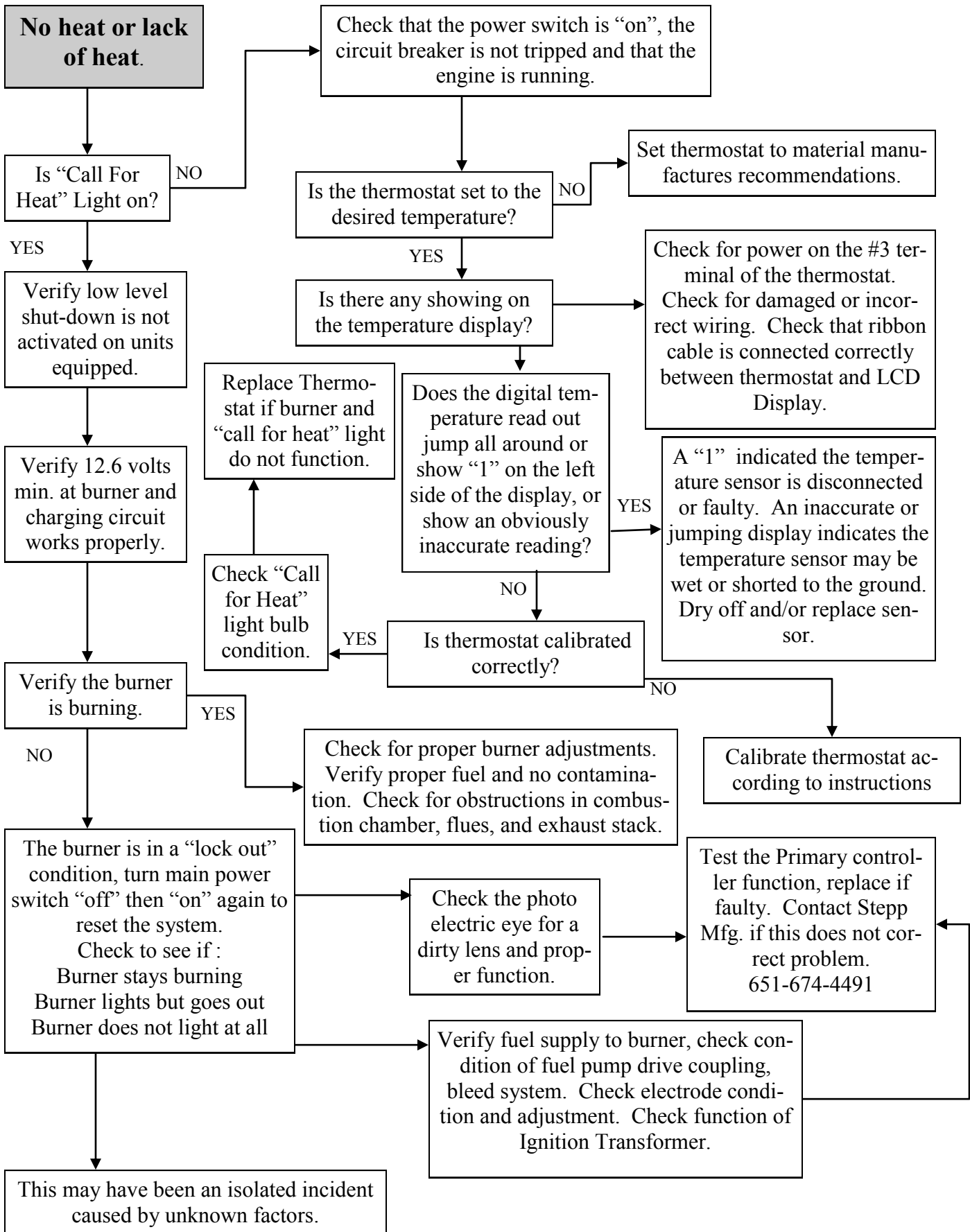



## Diesel Burner Component Test

**Primary Controller Burner mtd/hard wired.** The Primary Controller can be bench tested for proper operation using an automotive type 12 volt battery as a power source. Refer to the wiring schematic for wire identification.

1. Remove Controller from burner. Mark all wires for proper reassembly.
2. Using 2 test lights or volt meters, connect one to the blue wire, and one to the white/orange wire of the Controller. Connect the black leads of your test instruments to neg. ( - ) terminal of battery.
3. Connect the black wire from the Controller to neg. ( - ) terminal of battery.
4. Connect the red, white/red, and the white wires together, then connect these 3 wires to battery (+ )terminal. Both test instruments should show voltage for approximately 15 seconds. After 15 seconds the controller should "lock out" and no voltage will be present.
5. Repeat step 4, only this time connect the 2 yellow wires from the Controller together 3 seconds *after* applying power to the 3 wires of the Controller.

(This simulates the controller receiving a "flame" signal from the Photo Electric Eye)

The white/orange wire should show voltage as long as the controller is hooked to the battery. The blue wire should only show voltage for about 15 seconds.

Replace the controller if it fails any of these tests.

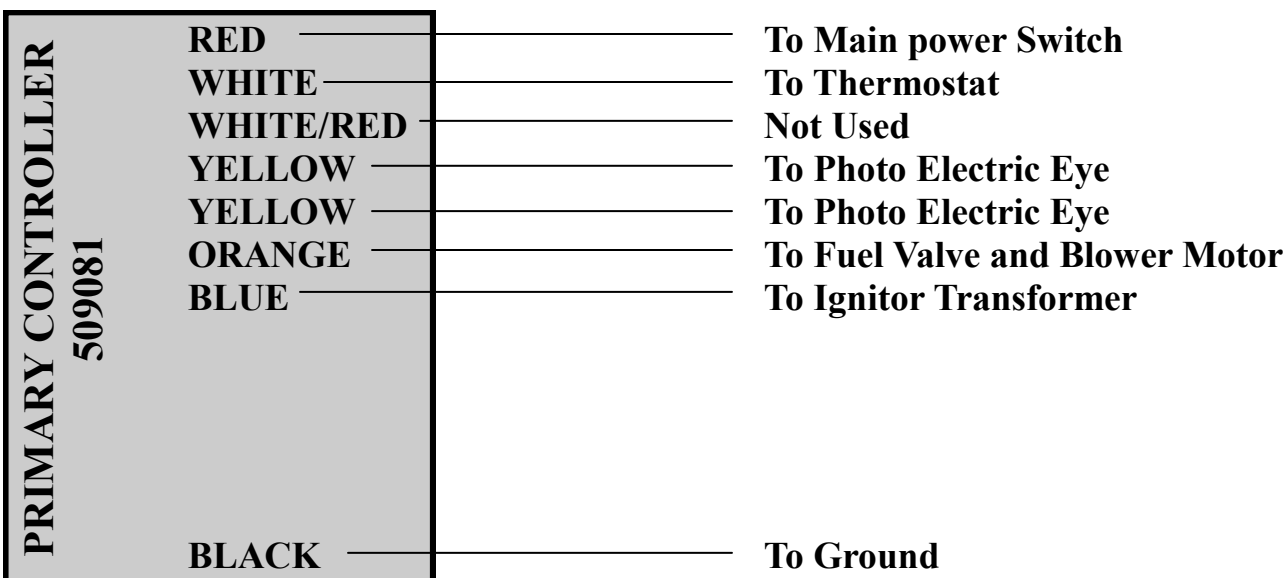

## **Photo Electric Eye**

The Photo Electric Eye can be bench tested for proper operation using an ohm meter. Assure the lens of the Photo Electric Eye is clean prior to testing.

1. Block off all light to the Photo Electric Eye. Test across the leads with your ohm meter, you should get an infinite resistance reading. (a lot of resistance)
2. Point the Photo Electric Eye at a light source, the brighter the light, the less resistance your ohm meter will show.

Replace the Photo Electric Eye if it does not respond in this way.

## **Fuel Valve**

The Fuel Valve can be bench tested for proper operation using an automotive type 12 volt battery as a power source.

1. Disconnect the 2 leads and remove the fuel lines from the Fuel Valve.
2. The valve should be closed when no power is available.
3. Apply 12 volts to the 2 leads and the valve should open.

Replace the Fuel Valve if it does not respond in this way.

## **Ignition Transformer** **WARNING - Shock Hazard, High Voltage up to 20,000 volts.**

1. Assure that 12 volts is being supplied to the transformer during the ignition cycle. (Refer to the Primary Controller tests.)
2. Check electrode condition and adjustment. Replace or adjust as necessary. Replace Ignition Transformer if unit won't produce sparks.

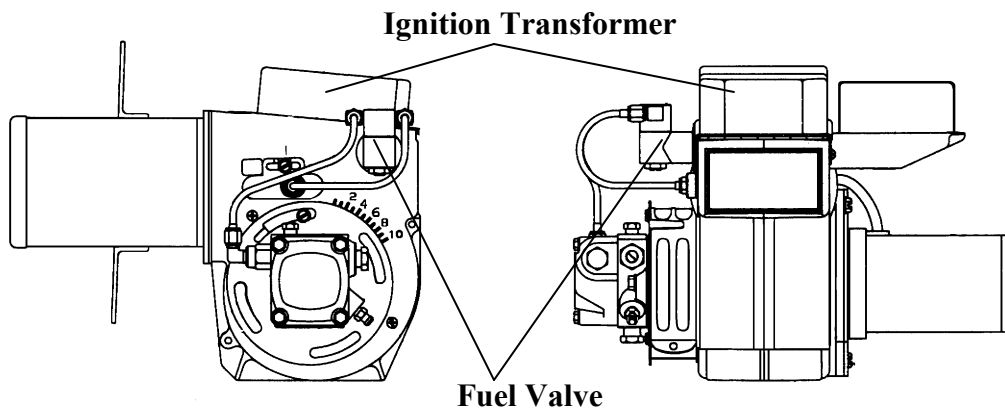

# REPLACEMENT PARTS

---

# REPLACEMENT PARTS

# DIESEL BURNER

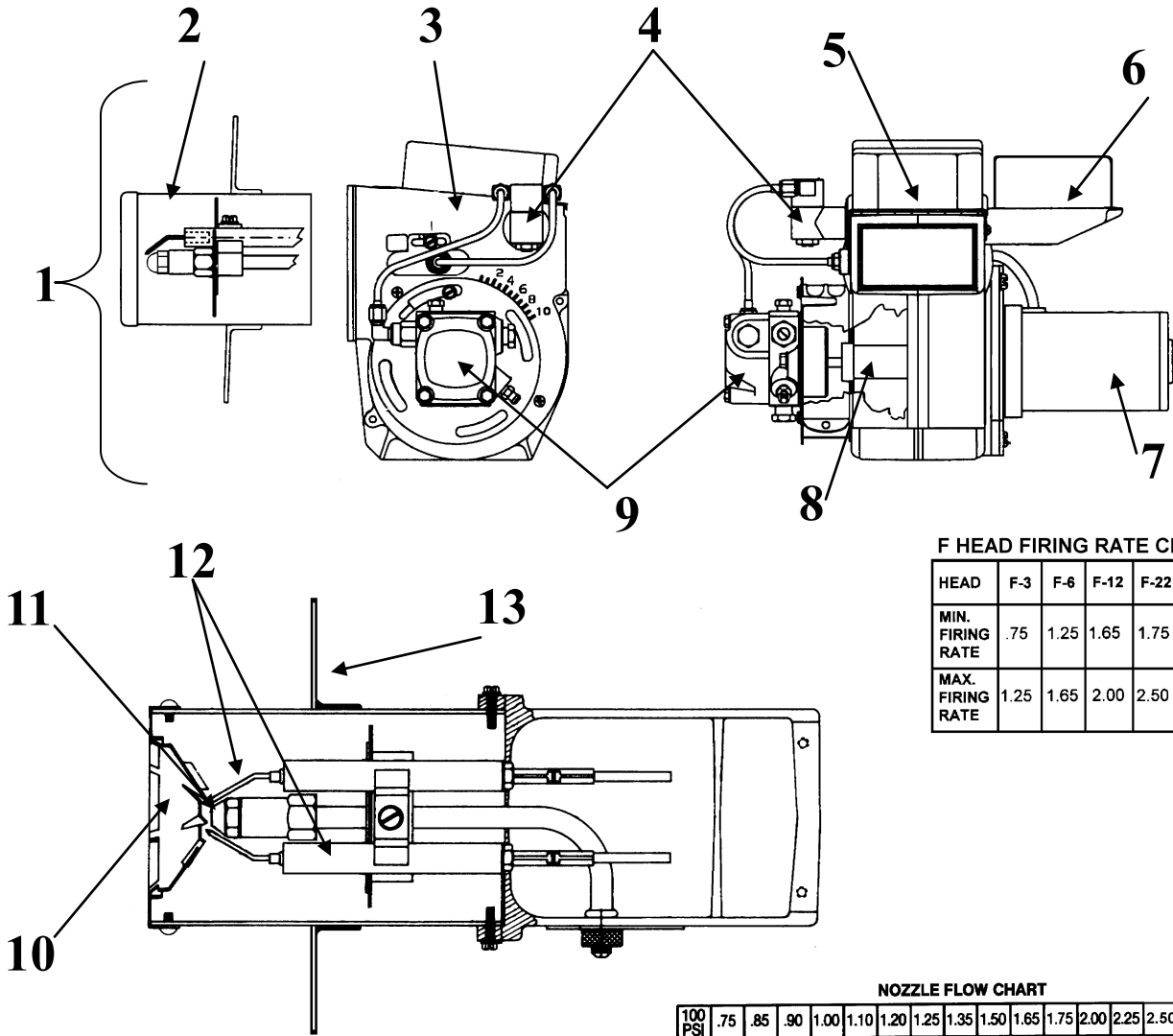

F HEAD FIRING RATE CHART

HEAD	F-3	F-6	F-12	F-22	F-31
MIN. FIRING RATE	.75	1.25	1.65	1.75	2.50
MAX. FIRING RATE	1.25	1.65	2.00	2.50	3.00

NOZZLE FLOW CHART

100 PSI	.75	.85	.90	1.00	1.10	1.20	1.25	1.35	1.50	1.65	1.75	2.00	2.25	2.50	2.75	3.00
140 PSI	.89	1.00	1.07	1.18	1.30	1.41	1.48	1.60	1.78	1.95	2.07	2.37	2.66	2.96	3.25	3.55

ITEM	QTY	DESCRIPTION	PART#
1	1	Burner, fuel oil, Beckett Assembly	A10008105-011
2	1	Air Tube	509070
3	1	Photo electric eye w/connectors (under ignition transformer)	A10007678
4	1	Valve, fuel control	509091
5	1	Ignition Transformer	509087
6	1	Primary Controller	A10008216
7	1	Motor, fan and pump	509092
8	1	Coupling, pump to motor	509086
9	1	Pump, burner fuel	509094
10	1	Fuel retention head, F31	P10005130
11	1	Nozzle, .3.0 GPM	P10005133
12	1	Electrode kit, igniter	509089
13	1	Mounting Flange	509071
**	1	Brush kit, motor	509072
**	1	Fuel Filter Element	509078

\*\* Not Shown

Note: Nozzle GPH rated at 100 psi.

# MISC.

# REPLACEMENT PARTS

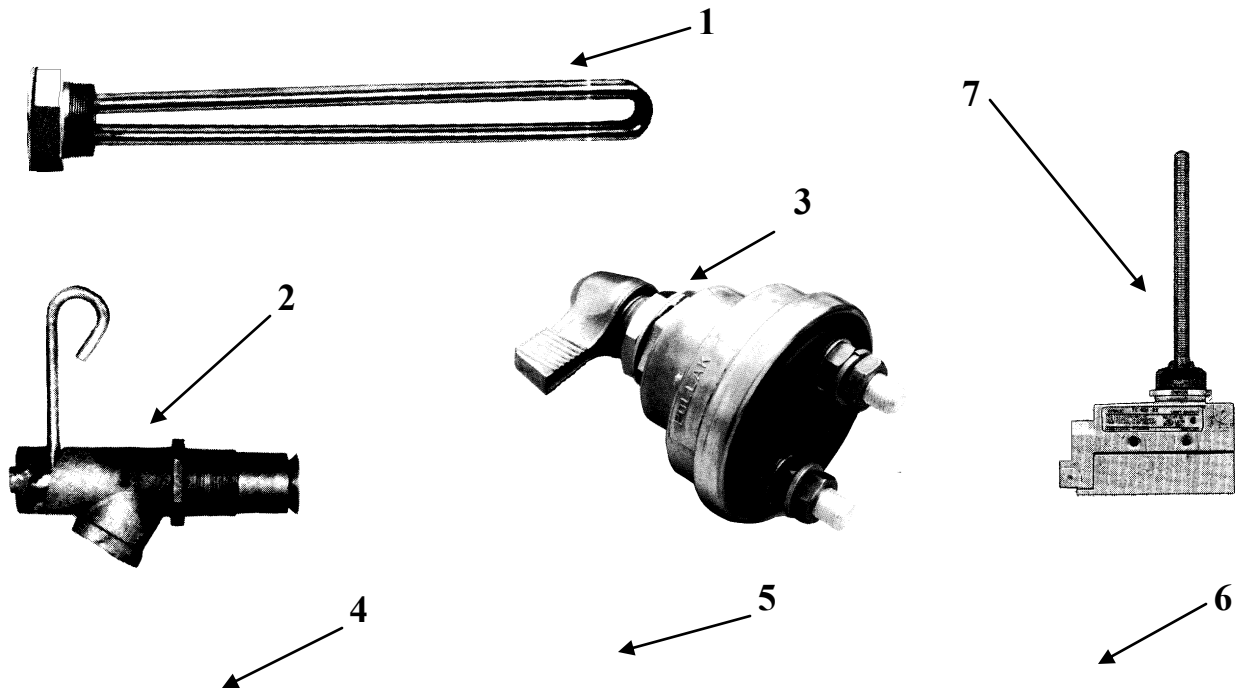

ITEM	QTY	DESCRIPTION	PART#
1	1	Over night heater, electric (optional)	520097
2	1	2.5" doc, draw-off valve	107006
3	1	Switch, heated hose and wand	526080
4	1	Oil Pressure Gauge	Call
5	1	Water Temperature Gauge	Call
6	1	Hour Meter	508038
7	2	Switch, pump saver & safety loading	526057

Note: Illustrations are for parts identification only. Illustrations may not represent actual parts.

# REPLACEMENT PARTS

# CONTROLS

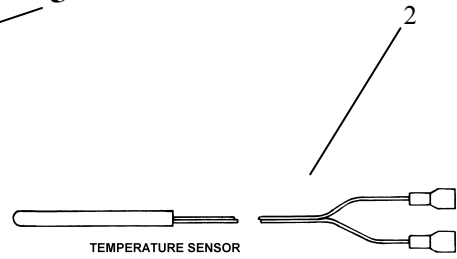
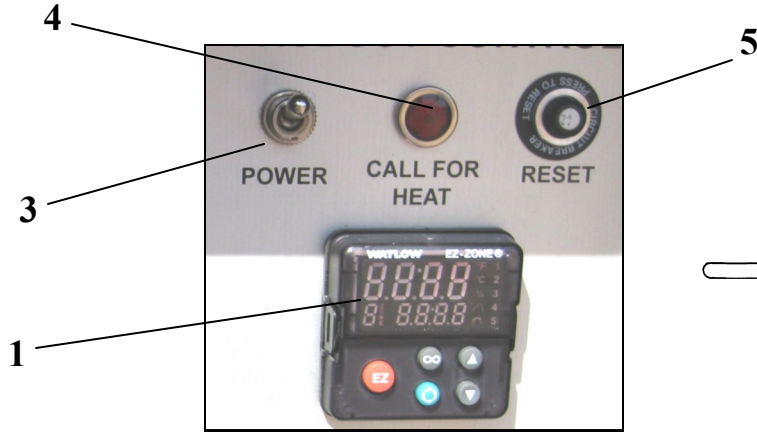

ITEM	QTY	DESCRIPTION	PART#
1	-	Thermostat, Watlow 0-550°, EZ 12V	EZ-ZONE- P10003540
2	-	Sensor, RTD Watlow 0-550°	A10001017
3	-	Switch- SPST Toggle ON/OFF	P10000180
**	-	Switch- ON/OFF/ON	P10002877
4	-	Light- Call For Heat 12V	P10000181
**	-	Hour Meter	P10002722
5	-	20 Amp Breaker	P10000179
** Not Shown			

# OVERHEAD BOOM

# REPLACEMENT PARTS

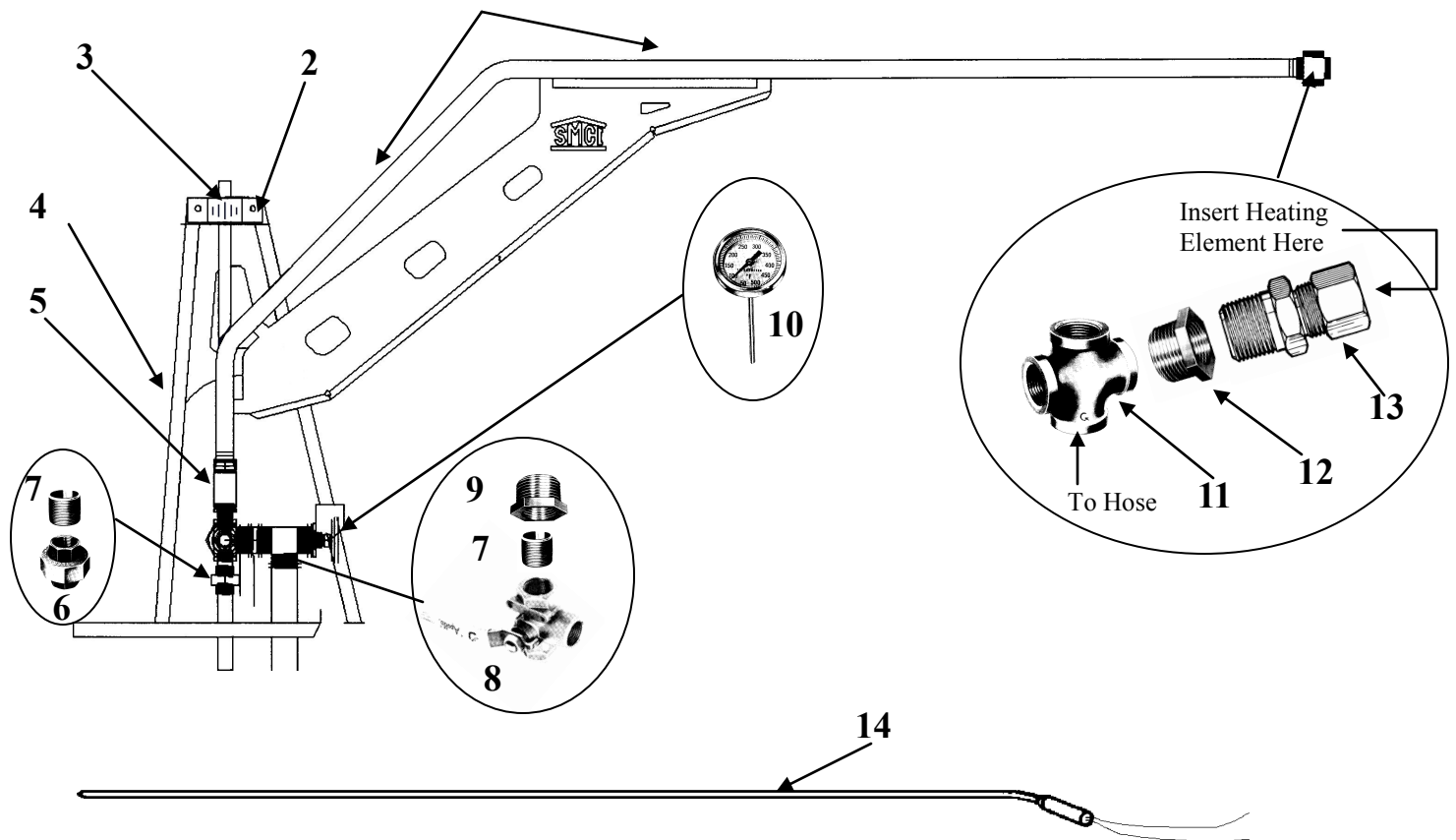

ITEM	QTY	DESCRIPTION	PART #
1	1	Boom	901280
2	1	Latch, boom transport and safety	901283
3	1	Support bearing	502006
4	1	Boom support (OJK 75 & 120)	901281
5	1	Boom swivel	520007
6	1	Union, 3/4"	513202
7	2	Nipple, 3/4" close	513211
8	1	Valve, 3-port WPC, 3/4"	517022
9	1	Bushing, reducing 1" x 3/4"	513706
10	1	Thermometer, 550 F. with 6" stem	516001
11	1	Cross Fitting	513254
12	1	Bushing, reducing 1" x 3/8"	513709
13	1	Compression Fitting 3/8"	520232
14	1	Heating Element, boom, includes *pre-wired connector	526112
*	9 ft	Inner Insulating for boom (specify length, priced per foot)	511007
*	8 sq ft	Outer Alumagard wrap for boom (specify length, priced per sq. foot)	511008
*	1	Wire Harness, boom	526115

\* - Not Shown

Note: Illustrations are for parts identification only. Illustrations may not represent actual parts.

# REPLACEMENT PARTS

# 8'/12' Heated Hose

*For Units equipped with 8'/12' Heated Hose w/Heated Overhead Boom*

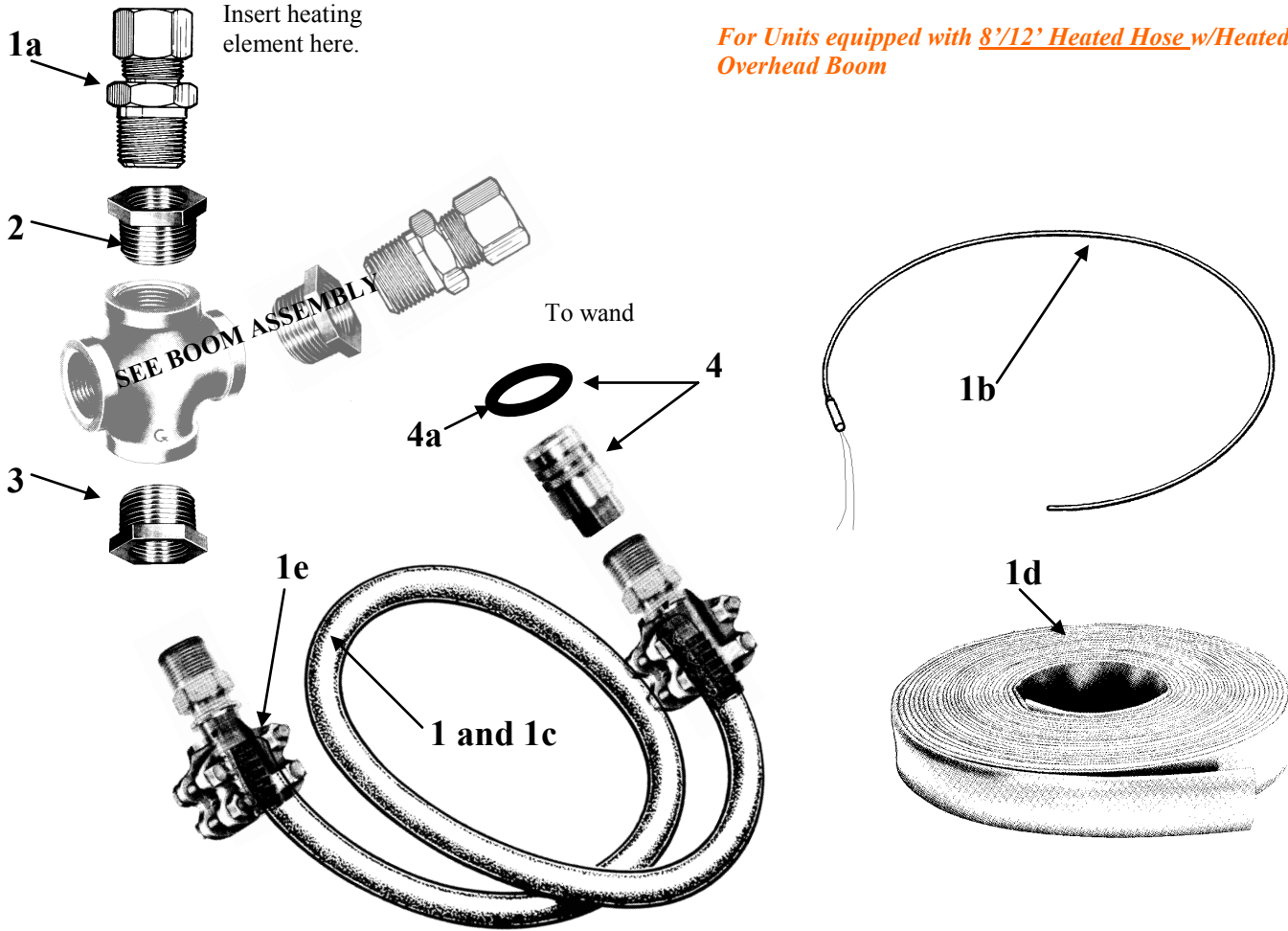

ITEM	QTY	DESCRIPTION	PART #
1	1	8' Hose Assembly with heating element .....	523089
	1	12' Hose Assembly with heating element .....	523093
1a	1	Compression Fitting 3/8" .....	520232
1b	1	8' Heating element, for hose, includes **connector .....	526112
	1	12' Heating element, for hose, includes **connector .....	526120
1c	1	8' Hose Assembly, less heating element .....	523088
	1	12' Hose Assembly, less heating element .....	523092
1d	AR	Safety Jacket, specify length .....	523080
1e	2	Clamp assembly (torque bolts to 21 ft lbs) .....	523087
**	1	Wire Harness & Connectors (in hose jacket) .....	Call
2	1	Bushing, reducing .....	513709
3	1	Bushing, reducing .....	513706
4	1	Quick Coupling, female .....	510003
4a	1	Seal, quick coupling .....	509999

\*\* - Not Shown



# 15'/20' HEATED HOSE

# REPLACEMENT PARTS

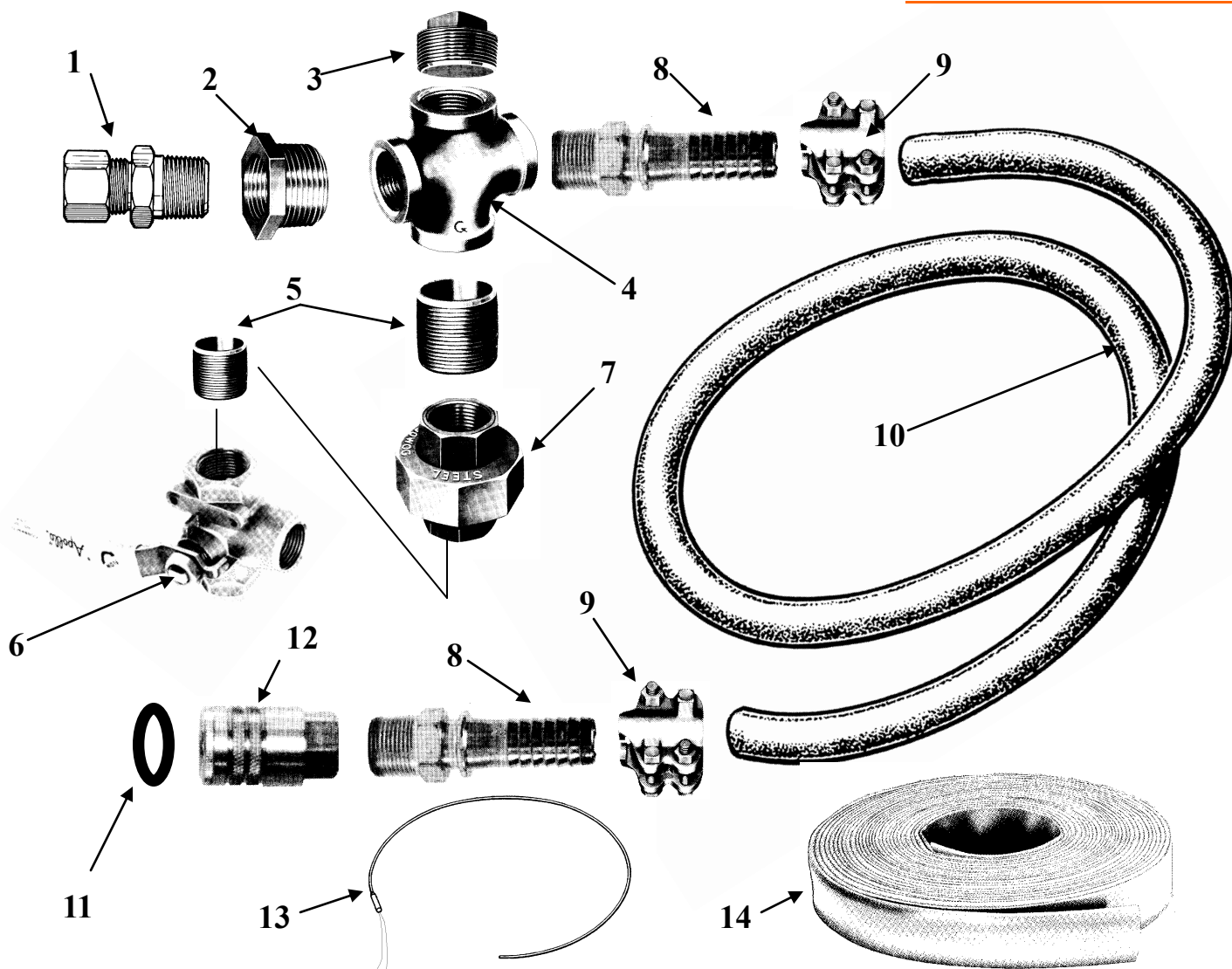

ITEM	QTY	DESCRIPTION	PART #
1	1	Compression Fitting assembly	523260
2	1	Bushing, reducing	513701
3	1	Plug	513208
4	1	Cross Fitting	513203
5	2	Nipple, close	513211
6	1	Valve, 3-port WPC	517022
7	1	Union	513202
8	2	Hose End	523084
9	2	Clamp assembly	523087
10	-	Hose only, specify 15 or 20 ft.	523083
11	1	Seal, quick coupling	509999
12	1	Quick Coupling, female	510003
13	1	Heating element, 15 ft.	526072
		Heating element, 20 ft.	526073
14	-	Safety Jacket, specify 15 or 20 ft.	523080
**	1	Hose Assembly Complete, 15 ft. (includes items 1-5, 7-10, 13-14)	523085
**	1	Hose Assembly Complete, 20 ft. (includes items 1-5, 7-10, 13-14)	523086
**	1	Hose Assembly, 15 ft. (less heating element, includes items 8-10, 14)	523081
**	1	Hose Assembly, 20 ft. (less heating element, includes items 8-10, 14)	523082

\*\* - Not Shown. Specify with or with out pump saver option.

Note: Illustrations are for parts identification only. Illustrations may not represent actual parts.

# REPLACEMENT PARTS

# TRIGGER WAND

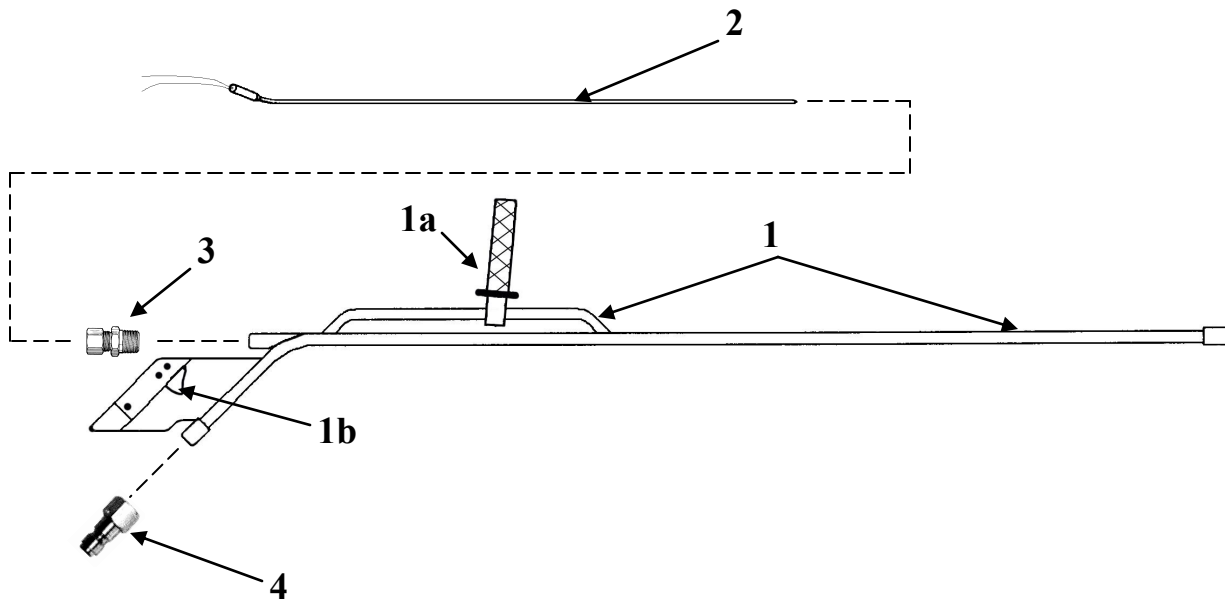

ITEM	QTY	DESCRIPTION	PART #
1	1	Wand assembly , LONG Trigger Style	204056
	1	Wand assembly, SHORT Trigger Style	204058
1a	1	Handle, Adjustable Slide	520022
1b	1	Switch, Trigger	526116
**		Wire Harness, Ultra-Lite Wand	Call
2	1	Heating Element, LONG Style	526113
	1	Heating Element, SHORT Style	526118
3	1	Compression Fitting, LONG Style 1/2"	523260
	1	Compression Fitting, SHORT Style 3/8"	520232
4	1	Quick coupling, Male Half	510002
**	1	Ball Valve w/Handle 1/2" , SHORT Style only	517047

Note: Illustrations are for parts identification only. Illustrations may not represent actual parts.

# HEATED WAND

# REPLACEMENT PARTS

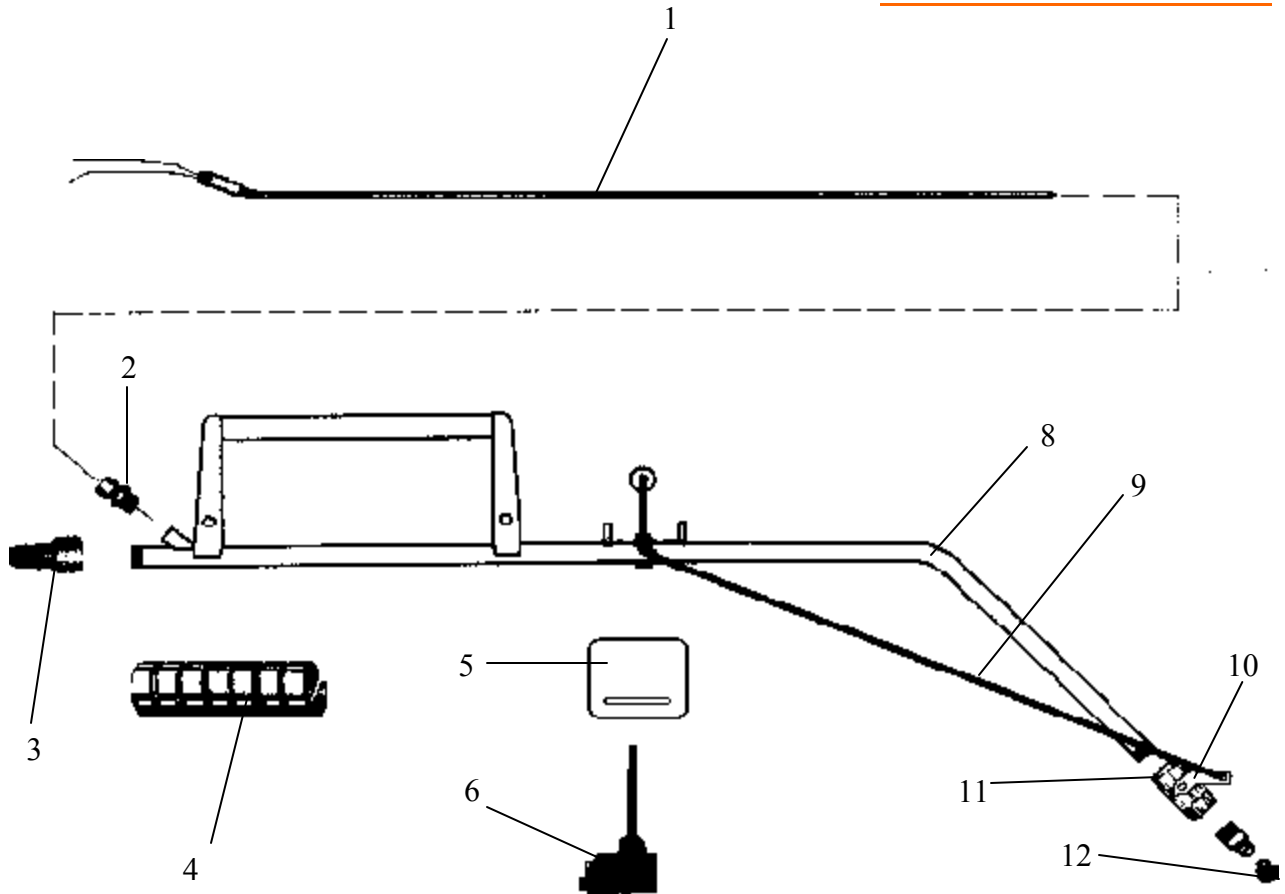

ITEM	QTY	DESCRIPTION	PART #
1	1	Heating Element	526074
2	1	Compression Fitting	523260
3	1	Quick Coupling, male	510002
4	10 ft	Insulating Wrap, wand	520114
5	1	Mounting Bracket, switch (pump saver option only)	Call
6	1	Switch, pump saver (pump saver option only)	526057
7	1	Control Handle, for steel wand	Call
	1	Control Handle with bushing, for aluminum wand	Call
8	1	Steel Spray Wand Assembly (includes items 4, 7-9)	Call
	1	Aluminum Wand, light weight, optional (includes items 4, 7-9)	Call
9	1	Actuating Rod	Call
10	1	Lever, valve	Call
11	1	Valve	517006
12	1	Spray Nozzle, ¼U9508	520060

Note: Illustrations are for parts identification only. Illustrations may not represent actual parts.

# REPLACEMENT PARTS

# NON HEATED WAND

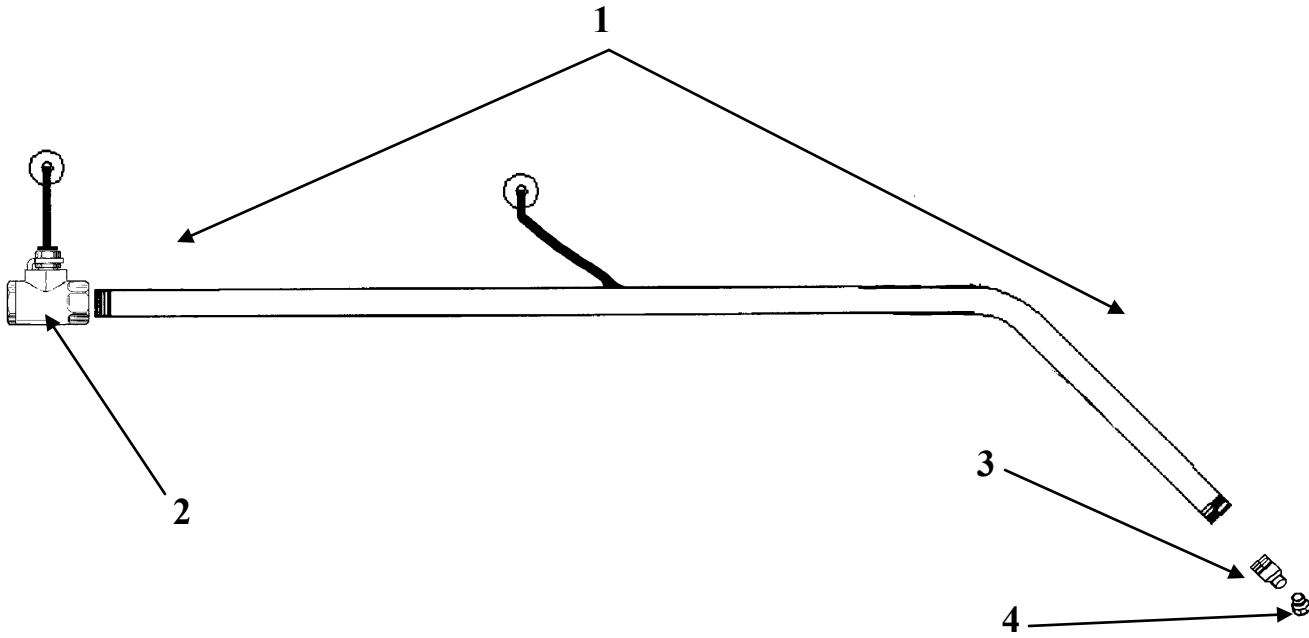

ITEM	QTY	DESCRIPTION	PART #
1	1	Wand assembly complete, steel (Includes items 1 - 4)	204004
	1	Wand assembly complete, light weight aluminum (Includes items 1 - 4)	204026
2	1	Valve	517006
3	1	Coupling	513809
4	1	Spray Nozzle, 9508	520060

Note: Illustrations are for parts identification only. Illustrations may not represent actual parts.

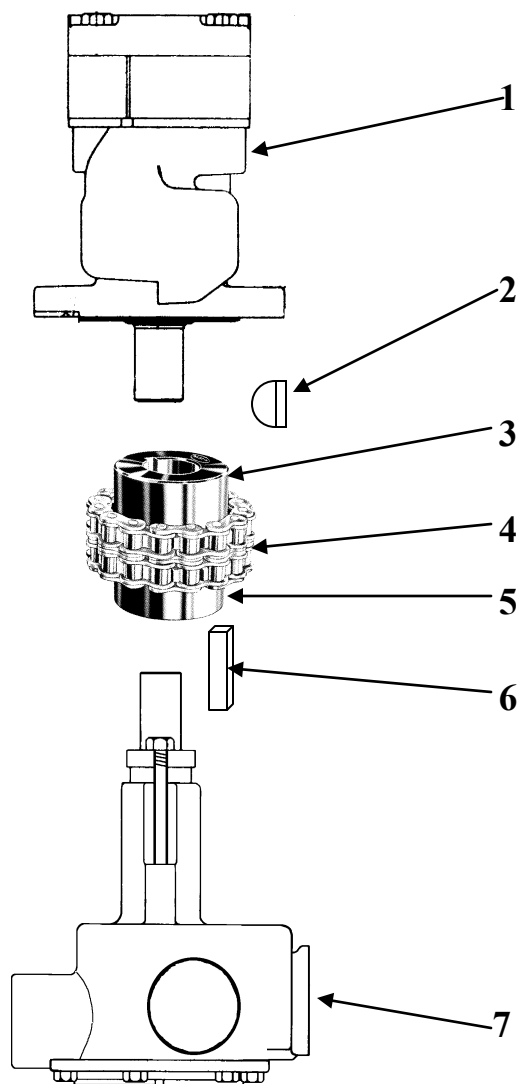

<b>ITEM</b>	<b>QTY</b>	<b>DESCRIPTION</b>	<b>PART #</b>
1	1	Motor, Hydraulic	Call
2	1	Woodruff Key, 1/4" x 1"R	522048
3	1	Chain Coupling Half, 1" bore	P10004555-004
4	1	Coupling Chain, 4016	P10004556
5	1	Chain Coupling Half, 1 1/8" bore	P1000455-005
6	2	Drive Key, 1/4x1/4	P10002019
7	1	Product Pump K124A L/RV	515081

Note: Illustrations are for parts identification only. Illustrations may not represent actual parts.

# REPLACEMENT PARTS

# PRODUCT PUMP

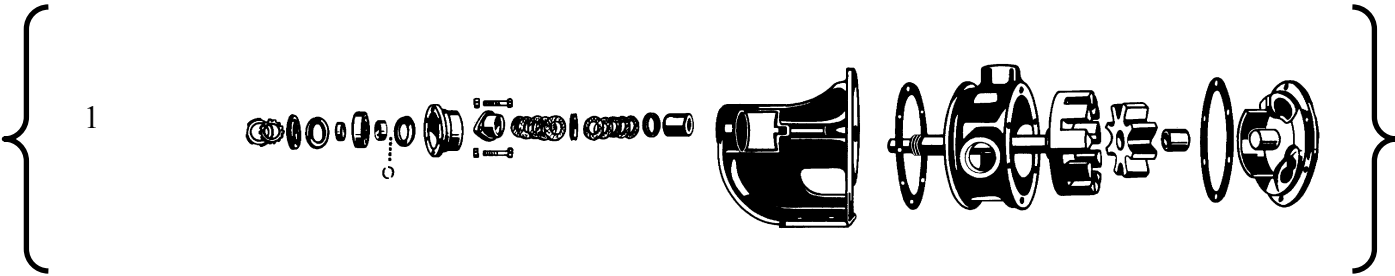

ITEM	QTY	DESCRIPTION	PART#
------	-----	-------------	-------

1	1	Oil Pump, K124A Less RV	515081
---	---	-------------------------	--------

Call for Pump break down on parts.

Note: Illustrations are for parts identification only. Illustrations may not represent actual parts. Items without part numbers are available by giving the part description and the serial number of the equipment.

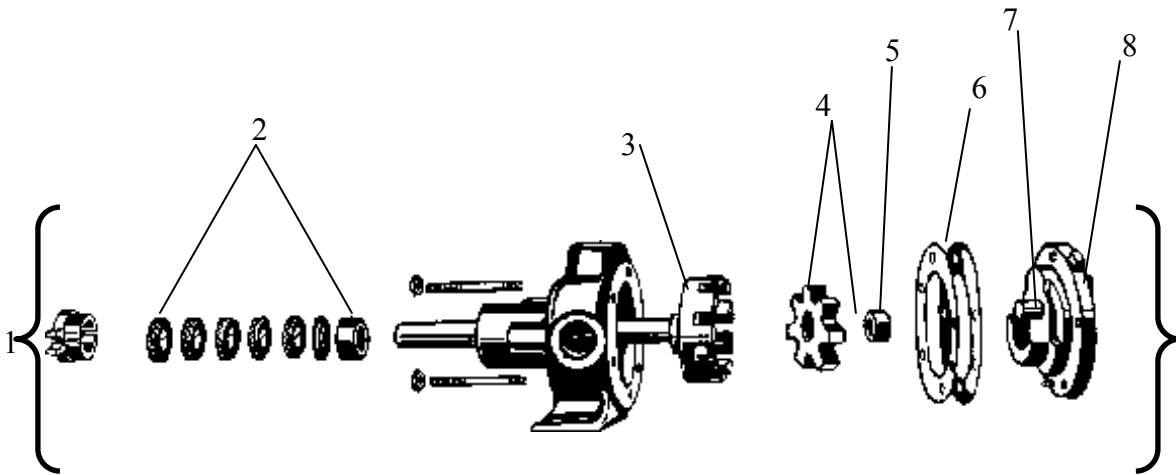

ITEM	QTY	DESCRIPTION	PART#
------	-----	-------------	-------

1	1	Oil Pump, complete	515063
2	5	Packing seal, shaft	515019
3	1	Rotor and Shaft	515031
4	1	Idler with bushing	515015
5	1	Bushing	515053
6	1	Gasket set, head - (for setting end clearance)	515016
7	1	Idler Pin	515052
8	1	Head (includes # 6)	515028

Note: Illustrations are for parts identification only. Illustrations may not represent actual parts. Items without part numbers are available by giving the part description and the serial number of the equipment.

# ALERNATOR/HYDRAULIC PUMP DRIVE

# REPLACEMENT PARTS

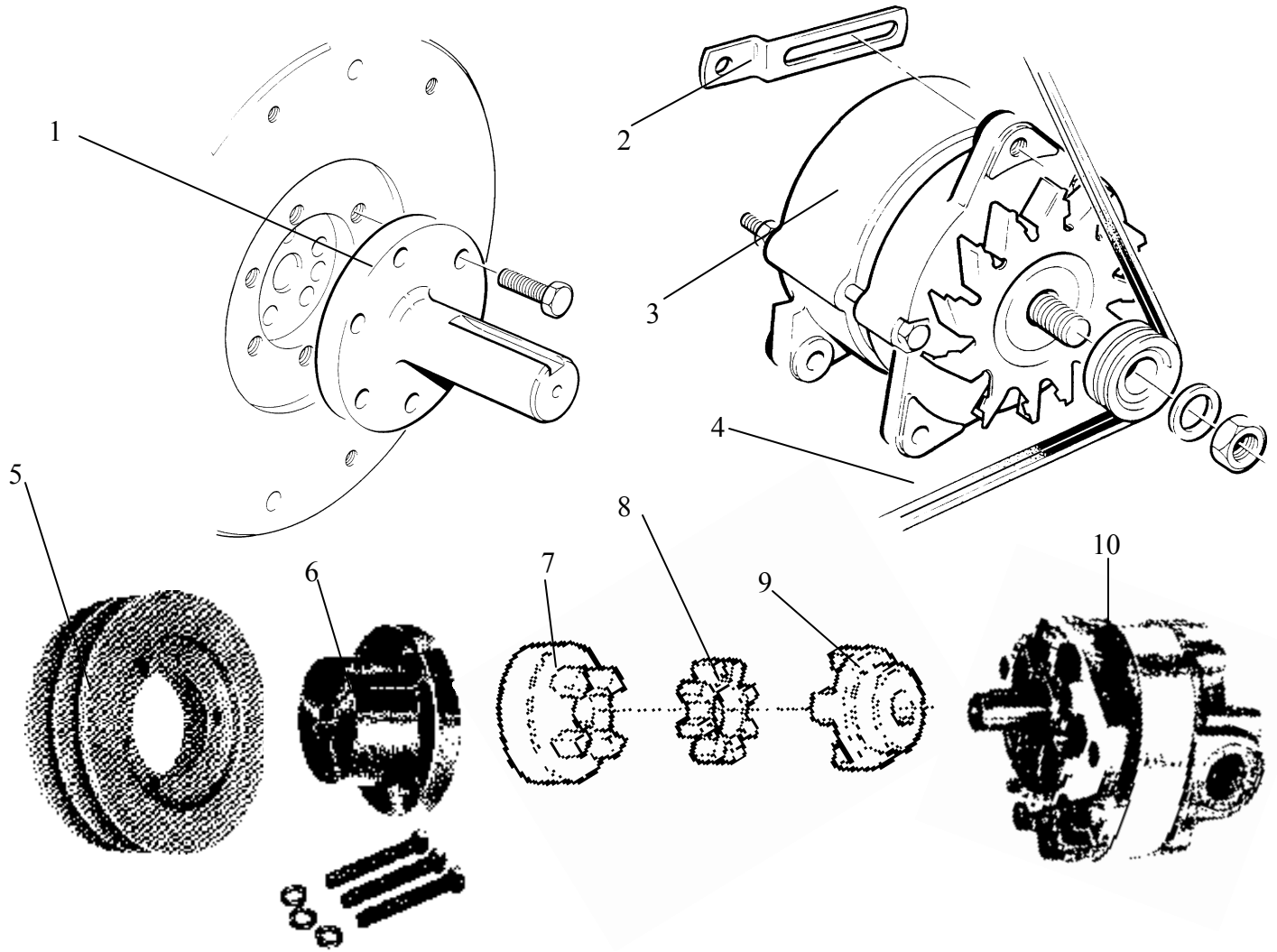

ITEM	QTY	DESCRIPTION	PART #
1	1	Stub Shaft, diesel engine only	901230
2	1	Adjusting Bracket, alternator, for diesel engine only	Call
3	1	Alternator, 24 volt	526058
4	2	V-Belt, alternator, diesel engine	514013
	2	V-Belt, alternator, gas engine	514011
5	1	Pulley	514020
6	1	Bushing, Pulley (includes bolts)	514022
7	1	Coupling Half, 1" bore	507063
8	1	Spider	507067
9	1	Coupling Half, 5/8" bore, used with diesel engine	507064
	1	Coupling Half, 9/16" bore, used with gas engine	507066
10	1	Pump, Hydraulic, used with diesel engine	510073
	1	Pump, Hydraulic, used with gas engine	510064

Note: Illustrations are for parts identification only. Illustrations may not represent actual parts.

# REPLACEMENT PARTS

# AGITATOR

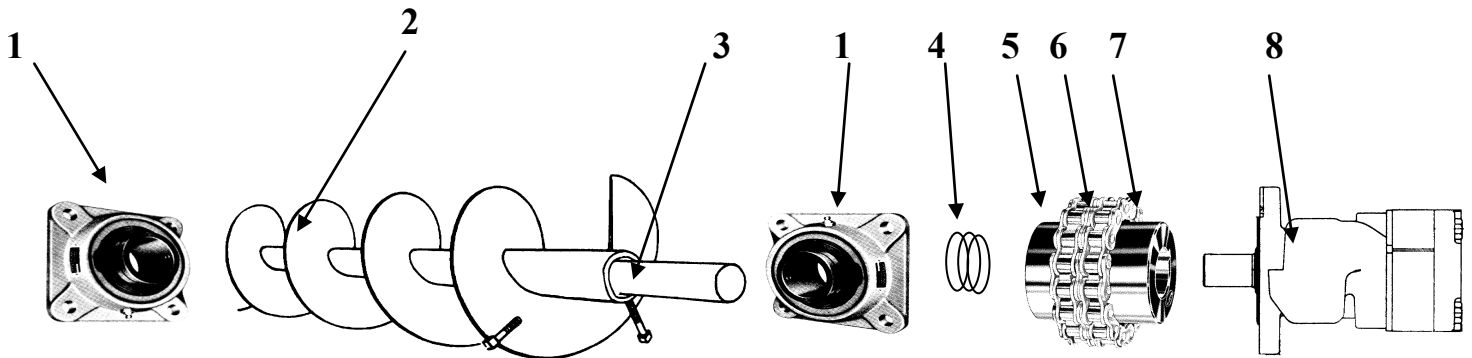

## ASSEMBLY DETAIL

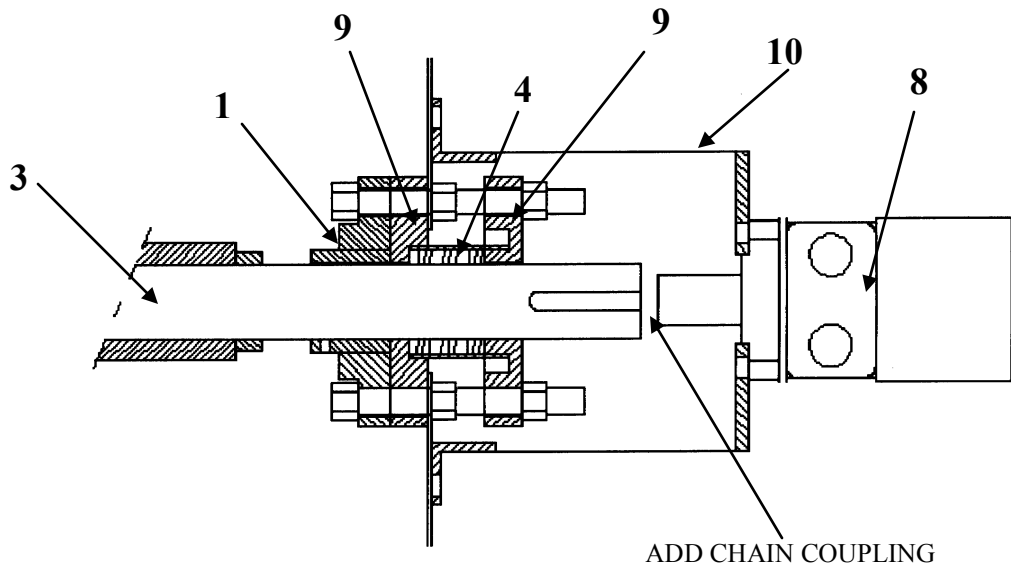

ITEM	QTY	DESCRIPTION	PART #
1	2	Bearing, Auger	502019
2	1	Auger	Give VIN
3	1	Shaft, Auger	Give VIN
4	3 ft	Seal Packing	515042
5	1	Chain Coupling Half, 1 1/2" bore	507009
6	1	Coupling Chain, 5016	507022
7	1	Chain Coupling Half, 1" bore	507008
8	1	Hydraulic Motor	510054
9	1	Packing Gland and Seat Assembly (includes items, 4, 9 and bolts)	901028
10	1	Mount for Hydraulic Motor	Give VIN

Note: Illustrations are for parts identification only. Illustrations may not represent actual parts. Part description and unit serial number are required to place orders for parts without numbers.



# MISC.

# REPLACEMENT PARTS

<u>ITEM</u>	<u>QTY</u>	<u>DESCRIPTION</u>	<u>PART#</u>
00	1	Main burner power switch	526039
00	1	Red 12v heat light	526038
00	1	20 amp circuit breaker	526094
00	1	Charging Resistor	526059
00	1	Fuel Pump, electric	Call
00	1	Oil drain valve, engine	508050
00	1	Fuel Gauge	509080
00	1	Cap Assembly, fuel tank	513414
00	1	Cap, hydraulic tank	513522
00	1	Warning Label and Decal Kit	Call
00	-	LUBE-TECH Heat Transfer Oil 460, 55 gallon drum.	603017
00	-	LUBE-TECH Heat Transfer Oil 460, 5 gallon pail.	603019
		(Used in oil jacketed equipment <i>without</i> oil circulation pumps)	
		(Refer to maintenance manual for oil capacities)	

# REPLACEMENT PARTS

# BRAKES AND AXLES

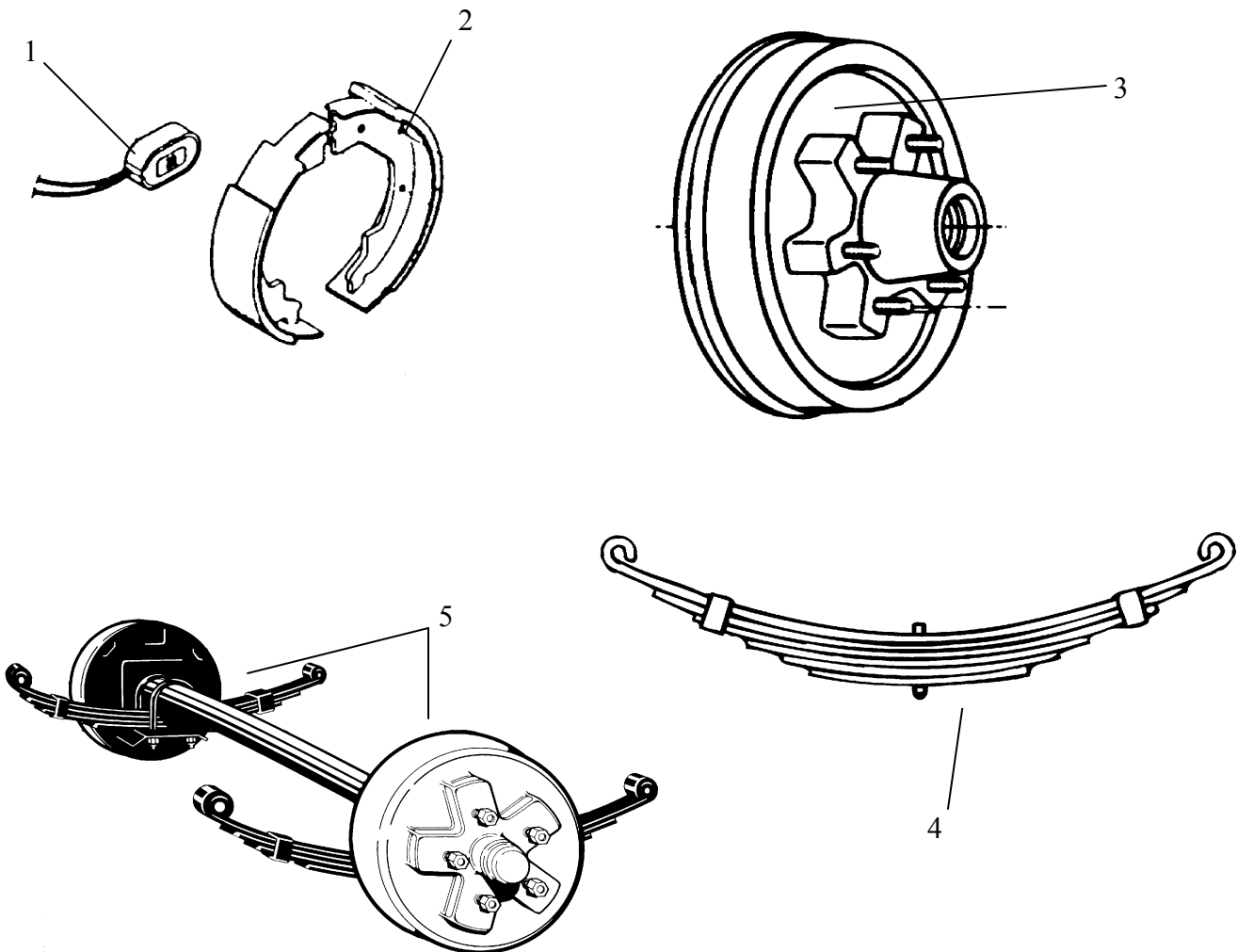

ITEM	QTY	DESCRIPTION	PART#
1	1	Magnet, electric brake (1 required for each wheel)	Give Serial #
2	1	Brake Shoe Set (1 set required for each wheel)	Give Serial #
3	1	Brake Drum and Hub assembly (1 required for each wheel)	Give Serial #
4	1	Leaf Spring assembly (1 required for each wheel)	Give Serial #
Complete replacement axle assemblies are available and include brakes, hubs, and springs.			
5	1	Axle assembly, complete, call for ordering information	Give Serial #
*	4	Wheel, call for ordering information	Give Serial #

\* - Not Shown

Note: Illustrations are for parts identification only. Illustrations may not represent actual parts.

### ORDERING INFORMATION:

Orders for suspension parts must include the equipment serial number.

Orders for brake parts must include the equipment serial number and brake drum dimensions. (diameter and width) Also specify electric or hydraulic brake system.

# MISC.

# REPLACEMENT PARTS

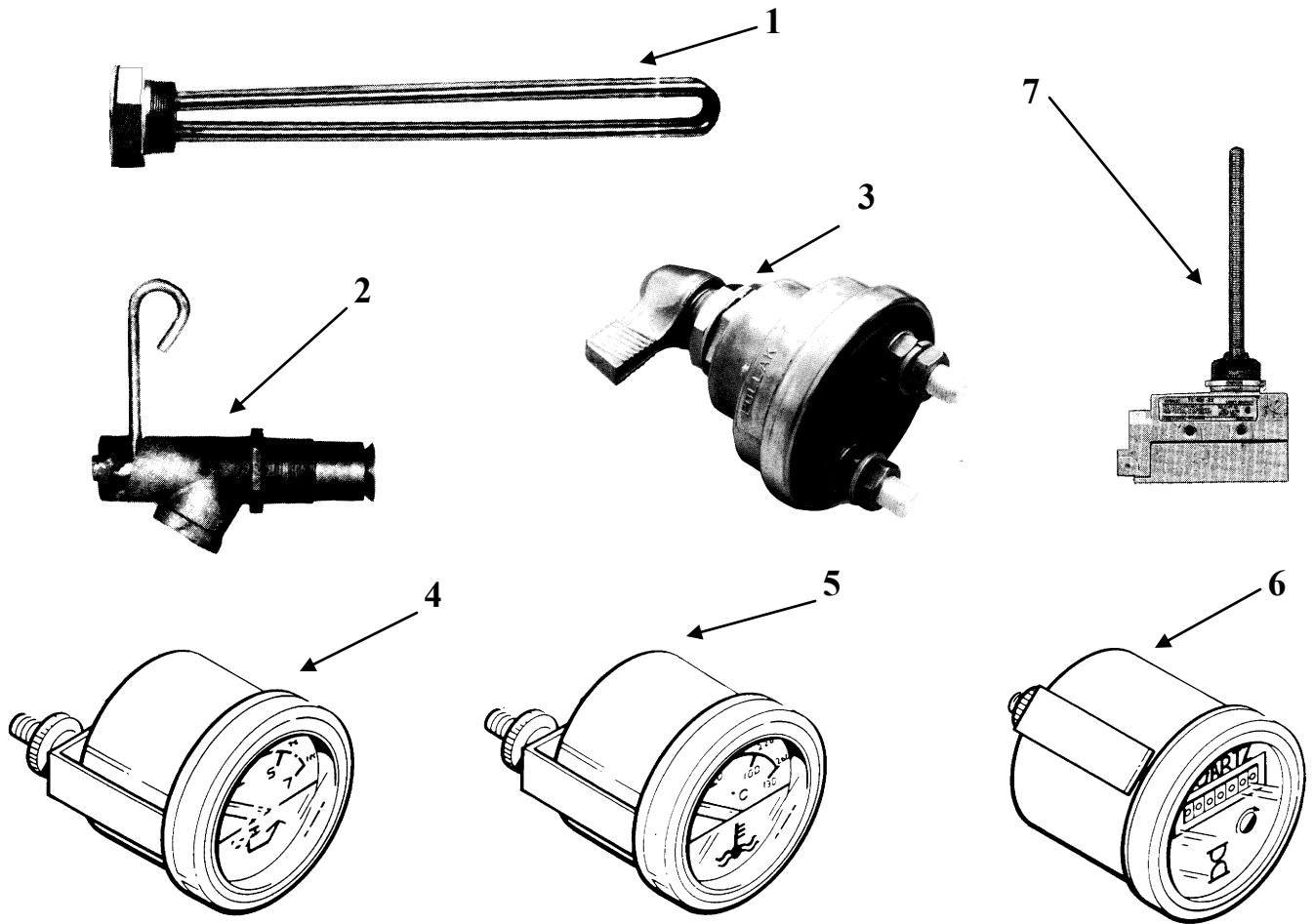

ITEM	QTY	DESCRIPTION	PART#
1	1	Over night heater, electric (optional)	520097
2	1	2.5" doc, draw-off valve	107006
3	1	Switch, heated hose and wand	526080
4	1	Oil Pressure Gauge	Call
5	1	Water Temperature Gauge	Call
6	1	Hour Meter	508038
7	2	Switch, pump saver & safety loading	526057

Note: Illustrations are for parts identification only. Illustrations may not represent actual parts.

NHTSA Reporting Safety Defects

If you believe that your vehicle has a defect in which could cause a crash or could cause injury or death, you should immediately inform the National Highway Traffic Safety Administration (NHTSA) in addition to notifying STEPP MANUFACTURING CO., INC..

If NHTSA receives similar complaints, it may open an investigation and if it finds that a safety defect exists in a group of vehicles, it may order a recall and remedy campaign. However, NHTSA cannot become involved in individual problems between you, your dealer, or STEPP MANUFACTURING CO., INC..

To Contact NHTSA, you may either call the Auto Safety Hotline toll-free at 1-888-327-4236 (TTY: 1-800-424-9153); go to <http://www.safercar.gov>; or Write to: NHTSA, US Department of Transportation, 1200 New Jersey Ave., S.E., Washington DC 20590. You can also obtain information about your motor vehicle safety from <http://www.safercar.gov>.

# WARRANTY GUIDE

---

# Stepp Mfg. Co.

## Consumer Warranty Guide

	Page
Table of Contents	
Introduction	2
Warranty Procedures Through A Dealer	2
Warranty Procedures Direct Through The Factory	2
Engine Warranty Claims	2
Equipment Owner Responsibilities	2
General Warranty Statement	3
Pro Rata Heated Asphalt Hose & Element Warranty	4

### **Stepp Manufacturing Co Inc**

12325 River Road • North Branch MN 55056-6225

Phone (651)674-4491 • Fax (651) 674-4221

[jason@Steppmfg.com](mailto:jason@Steppmfg.com)      [www.SteppMfg.com](http://www.SteppMfg.com)

## Introduction

Congratulations on your purchase of Stepp Asphalt Maintenance Equipment. Your equipment has been designed and constructed to give you the most in performance, ease of use, and reliability. It is our desire that you will find operating the equipment both productive and profitable.

This Warranty Guide has been prepared to help you in the unlikely event that your equipment requires warranty service. You can rest assured that Stepp Mfg will assist in any way we can to get your equipment repaired and back on the job as quickly as possible.

## Warranty Procedures Through A Dealer

If your equipment requires repair during the warranty period, contact your dealer and arrange to bring the unit to him for repair. The dealer will require purchase date information, where the machine was purchased, and the serial number of the equipment. This information is needed so the dealer can submit a warranty claim. The dealer will repair your equipment at no charge to you under the provisions of the warranty policy.

## Warranty Procedures Direct Through The Factory (When there is no servicing dealer in your area)

Contact Stepp Mfg at (800)359-8167 if there is no servicing dealer located in your area.

In this situation it may be advantageous for you to repair the machine and be reimbursed direct from the factory for warranty repairs. If you do not have the facilities or the technicians to perform the repair, the unit can be brought to a local repair facility for the warranty work. In either case Stepp Mfg *MUST* be contacted and a *Warranty Authorization Number* issued prior to any work being performed.

If parts are required for the warranty repair, contact Stepp Mfg for replacements. When warranty replacement parts are shipped to you, a prepaid UPS shipping label will be included. Be sure to “tag” the defective parts with the *Warranty Authorization Number* then package them in the same box the new parts were shipped in. Affix the UPS shipping label to the outside of the box and return to Stepp Mfg as soon as practical.

You will be billed for all parts shipped, however, when the defective parts are returned and evaluated, you will receive credit for the cost of the parts plus any shipping charges. Thus it is important that all defective parts are returned to Stepp Mfg in a timely matter.

## Engine Warranty Claims

When a warranty issue develops with the engine, bring the unit to the engine manufacturer's nearest authorized service center for repair. Be prepared to supply them with proof of purchase information with purchase dates.

Stepp Mfg can not process engine warranty claims, however we will be happy to offer assistance in locating the nearest service center.

## Equipment Owner Responsibilities

As the equipment owner you are responsible for:

- Using the equipment in accordance with the correct operating procedures as shown in the operators manual.
- Assuring all maintenance items are completed in accordance with the operators/maintenance manuals.
- Transporting the equipment to the place where warranty repairs can be completed.
- Supplying purchase date and serial number information to establish warranty coverage.

Stepp Manufacturing Co Inc

12325 River Road • North Branch MN 55056-6225

Phone (651)674-4491 • Fax (651) 674-4221

jason@Steppmfg.com      www.SteppMfg.com

## *General Warranty Statement*

### *Stepp Mfg 1 Year Limited Warranty*

Stepp Manufacturing Company Inc. hereby warrants to the original purchaser that products manufactured by Stepp Mfg will be free from defects in material and workmanship for a period of 1 year from the date of purchase.

Stepp Mfg, at its discretion, will provide for the repair or replacement of any part found upon examination by Stepp Mfg to be defective, except as noted below. Such repair or replacement will be free of charge to the original purchaser for a period of 1 year from the date of purchase, except as noted below.

#### **No warranty is extended to cover:**

- Product pump wear or damage caused by foreign object.
- Routine maintenance, cleaning, and adjustments.
- Parts or components that have been altered, misused, improperly adjusted or maintained.
- Transportation to and from the place of warranty repair.
- Removal of material from equipment.

#### **The following items are covered solely by their manufactures warranty:**

- Engines
- Hydraulic components
- Burners
- Pumps
- Tires
- Other component parts

#### **The following items are covered by a pro rata warranty:**

- Hoses that carry heated materials.
- Heating Elements for hoses and wands.

#### **Disclaimer of further warranty:**

Stepp Mfg makes no warranty, expressed or implied, other than this warranty. The implied warranties of merchantability and fitness for particular purpose are hereby disclaimed. Repair or replacement of products or parts proving to be defective in material or workmanship shall be the exclusive remedy for breach of this warranty.

Stepp Mfg shall not be liable for incidental or consequential damages. Including but not limited to, damages for inconvenience, rental or purchase of replacement equipment, for loss of profits, or other loss resulting from breach of this warranty.

Stepp Mfg reserves the right to incorporate any changes in design into its products without obligation to make such changes on products previously manufactured.

#### **Stepp Manufacturing Co Inc**

12325 River Road • North Branch MN 55056-6225  
Phone (651)674-4491 • Fax (651) 674-4221  
jason@Steppmfg.com      www.SteppMfg.com





## *Heated Asphalt Hose and Heating Element 12 Month Pro Rata Limited Warranty*

*Effective for Oil Jacketed Kettles and Equipment Delivered After 8/1/00*

Stepp Manufacturing Company Inc. hereby warrants to the original purchaser on a pro rata basis that the heated asphalt hose and hose heating element installed on new Stepp manufactured equipment will be free from defects in material and workmanship for a period of 12 months.

If a hose or heating element fails under normal use during the warranty period, Stepp Mfg will supply a replacement hose or heating element, and provide for ½ hour installation labor on a pro rata adjustment basis.

- If the failure occurs under normal use within the first 3 months, Stepp Mfg will supply a replacement and provide for ½ hour installation labor at no charge to the customer.

- If the failure occurs under normal use within the 4th through 12th months, Stepp Mfg will supply a replacement and provide for ½ hour installation labor on a pro rata basis.

The pro rata adjustment is based on the total number of months elapsed since the purchase date of the new equipment divided by 12. This rate is then applied to the ½ hour labor rate and the current suggested retail price of the proper replacement hose or heating element supplied by Stepp Mfg. This is the amount the customer will have to pay.

In no case will the warranty coverage extend beyond 12 months from the original purchase date of the new equipment. Physical damage is not covered by warranty. Physical damage may include but is not limited to:

- Broken heating elements (typically caused by repeated bending to less than a 1 foot radius).
- Hoses burnt from the inside (typically caused by operating the heating elements in an empty hose, refer to the operators manual for proper operating procedures).
- External cuts or abrasion on hose, etc.

The chart below shows the pro rated amount (percentage of retail price and labor) that warranty and the customer will pay towards a replacement hose or heating element under this warranty policy.

	<b>Warranty pays</b>	<b>Customer Pays</b>
<u>Failure at</u>		
0-1 month	100%	0
1-2 months	100%	0
2-3 months	100%	0
3-4 months	75%	25%
4-5 months	66%	34%
5-6 months	58%	42%
6-7 months	50%	50%
7-8 months	42%	58%
8-9 months	34%	66%
9-10 months	25%	75%
10-11 months	17%	83%
11-12 months	8%	92%
After 12 months	0	100%

Note: 30 days is considered a month. Example: Failure at 2-3 months means failure between 61 and 90 days.

# Stepp Mfg. Co. Inc.

12325 River Rd. North Branch MN. 55056

<b>Customer Name</b>	<b>Phone #</b>	<b>Equipment Model #</b>	<b>Equipment Serial #</b>	
<b>Street Address</b>		<b>Hour Meter</b>	<b>Purchase Date</b>	
<b>City/State</b>	<b>Zip Code</b>	<b>Purchased From</b> (Dealer Name or Direct From Stepp Mfg)		
<b>Warranty Performed By: Company Name</b>			<b>Date of Malfunction</b>	
<b>Address</b>	<b>City</b>	<b>State</b>	<b>Zip</b>	<b>Date of Repair</b>
<b>Contact Name</b>	<b>Signature</b>			<b>Phone #</b>

**Describe Symptom** (be specific, e.g. "Burner ignites and runs for 35 seconds, then goes out." Wording such as "Burner does not work" is not adequate.)

**Describe Problem Found** (be specific, e.g. "Part failed due to loose connection resulting in misalignment and premature wear." Wording such as "faulty part" is not adequate.)

**Action Taken to Correct Problem** (be specific, e.g. "Removed damaged section of wire harness, soldered new leads in place and insulated splices with heat shrink tubing." Wording such as "repaired wiring" is not adequate.)

<b>Labor Time to Correct Problem</b> (if multiple repairs were made, list the labor time for each repair separately, or submit separate warranty claims) <b>Repair</b>	<b>Office Use Only</b>	<b>Parts &amp; Supplies Used in Repair</b>			<b>Office Use Only</b>
		<b>QTY</b>	<b>Description</b>	<b>Part#</b>	
<b>Labor Time</b>					

## Parts Return

All parts replaced should be tagged with the warranty authorization number and a copy of the this claim. Retain all parts until credit, or a *Warranty Parts Return Request*, is received from the factory. When requested, returned the parts, along with this claim, to Stepp Mfg, 12325 River Road, North Branch, MN 55056. If defective parts are not returned within 10 days, or this warranty claim does not accompany the returned parts, the claim will be denied.

**Office Use Only** - Do not write in the area below.

**Date Claim/Parts Received**                      **Claim Reviewed By**                      **Date**

**Is This A Warrantable Claim?**                      \_\_\_ Yes                      \_\_\_ NO

Explanation:

 **Warranty Amount:**  
Parts                      Labor                      Total Credit                      Credit Invoice #

# Stepp Mfg

12325 River Road  
North Branch MN  
55056

## Warranty Parts Return Request

Dealer/Service Center:

Reference:

- Warranty Authorization # \_\_\_\_\_ Dated \_\_\_\_\_
- Serial # \_\_\_\_\_
- Owner \_\_\_\_\_

Please return the parts listed below for warranty evaluation using the following procedure.

1. Attach this request to the parts.
2. Package parts for shipment.
3. Adhere the enclosed Pre-paid UPS Shipping label to the package.

*Note: If no shipping label was sent with this request, call Stepp Mfg (800) 359-8167 with the package dimensions and weight, then a prepaid shipping label will be sent to you.*

4. Ship package to Stepp Mfg within 10 days of the date of this request.

The following parts are requested to be returned for warranty evaluation.

(Note: Failure to return requested parts will result in denial of warranty coverage.)

<u>Qty.</u>	<u>Part Number</u>	<u>Description</u>
-------------	--------------------	--------------------



# **WATLOW PROGRAMMING**

---

# Watlow 12v Series PM Temperature Controller

## Operators Programming Sequence for 12 volt devices. PN EZ-ZONE– P1003540

This programming sequence is taken from the manufacturers programming manual for this controller and reduced to eliminate the non-essential entries. Please follow the entries carefully and if any questions arise because of misunderstanding the instructions, see your supervisor or call the factory for clarification. **To view the entire EZ-Zone PM Controller Users Manual, go to [www.watlow.com](http://www.watlow.com), search on *EZONE PM Users Manual*.**

If at any time during the entries you feel that you have entered an incorrect entry and want to restart the procedure from the beginning, simply press the Infinity key to return to Home Page from any page or parameter. After 60 seconds with no key presses, the controller reverts to the Home Page.



The EZ-Zone PM Controller has four menus that are used to determine the configuration and operation of the controller. They are the Home Page, Setup Page, Operations Parameters Page, and the Factory Page. If you are installing the EZ-Zone PM Controller, you will need to determine the proper settings for all pages. The controller is preset at the factory prior to delivery of the equipment and is ready for operations. Always confirm that the controller is programmed correctly and operating correctly under normal operating conditions.

**Caution:** Pay particular attention to the h.SP (High Temperature Set point) setting for max. product application temperature that is entered on the Setup Page at step 7-8.

**Do not set the High Temperature Set Point any higher than the product manufacturer maximum application temperature recommendations. Do not hesitate to ask your supervisor or call the factory for the correct setting if any questions or concerns arise.**

## Watlow Series PM-12 volt controller

### Sample Display Illustrations

- This display shows a typical temperature selection by the operator.
- Upper display shows actual product temperature in red color.
- Lower display shows operator desired maximum temp setting in green color.
- Set the desired maximum temp with the up and down keys.



**Operator will not be able to exceed the maximum temperature set point as shown in the programming procedure in the following pages.**

**Do not hesitate to ask your supervisor for the correct setting if any questions or concerns arise.**

# Watlow Series PM-12volt Temperature Controller

## Operators Programming Sequence for 12 volt devices

*This programming sequence is taken from the manufacturers programming manual for this controller and condensed to eliminate the non-essential entries for ease of setup. Please follow the entries carefully and if any questions arise because of misunderstanding the instructions, please call the manufacturer for clarification.*

If at any time during the entries you feel that you have entered an incorrect entry and want to restart the procedure from the beginning, simply press the up arrow and the down arrow at the same time to erase all entries and begin the procedure from the beginning.

### Menu Structure and Programming

The Series PM Controller has four menus that are used to determine the configuration and operation of the controller. They are the Home Menu, Setup Menu, Operations Menu and the Factory Menu. If you are installing the Series PM Controller, you will need to determine the proper settings for all menus. If the controller is already installed in the equipment that you have purchased, you may only need to set a few of the parameters to adjust the controller to your specific usage of the equipment. The Setup Menu displays the parameters that configure the Series PM Controller to fit your application. When installed on new equipment, the controller is preset at the factory prior to delivery of the equipment and is ready for operations. Always confirm that the controller is programmed correctly and operating correctly under normal operating conditions.

**Caution:** Pay particular attention to the h.SP setting for max. product temperature. Do not set any higher than the product manufacturer maximum application temperature. Do not hesitate to ask your supervisor for the correct setting if any questions or concerns arise.



# Watlow Series PM-12volt Temperature Controller

## Operators Programming Sequence for 12 volt devices

Home Menu:

### Procedure for programming the Series PM-12 volt Watlow Control.

**Step 1:** Connect all wires to Watlow control including RTD (temp sensor).

**Step 2:** Connect power to Watlow controller.

**Step 3:** Enter the Setup menu. (press both the **up and down** arrow keys for 6 seconds).  
**A1** will appear in the upper display and **SEt** will appear in the lower display.

**Note:**

*You will have to pass through the Operations menu to get to the Setup menu.  
 Hold the up and down arrow keys simultaneously for 6 seconds to step through the menus.*

**Step 4:** Once **A1** is in the upper display, and **SEt** is in the lower display, you are in the Setup menu. If not, press the **infinity key** to return to the Home page and redo step 3.

**Step 5:** Press the **Advance key**. Use the **up or down** keys to change values.

	<u>Parameter</u>	<u>Value</u>	<u>Description</u>	<u>Caution</u>
5-1	<b>SEn</b> Advance key	<b>ro.1H</b>	sensor type	<b>Do not enter { rl.OH }</b>
5-2	<b>rt.L</b> Advance key	<b>2</b>	RTD leads	
5-3	<b>FIL</b> Advance key	<b>0.5</b>	Filler type	
5-4	<b>i.Er</b> Advance key	<b>off</b>	error latching	
5-5	<b>dEC</b> Advance key	<b>0</b>	decimal	

**Step 6:** After pressing the **Advance key**, after parameter **dEC**, you will return to the parameter **.SEn**. Press the **infinity** key to return to the Setup menu. Display will show **{ Ai Set }**.

**Step 7:** Press either the **up or down** key to select the Loop submenu. **LOOP** will be in the upper display and **SEt** will be in the lower display. If this is shown, press the **advance key** to enter the Loop submenu. (once in the submenu, use the **up or down** key to change the parameter values).

	<u>Parameter</u>	<u>Value</u>	<u>Description</u>
7-1	<b>h.Ag</b> Advance key	<b>on.of</b>	<b>heat algorithm</b>
7-2	<b>C.Ag</b> Advance key	<b>off</b>	<b>cool algorithm</b>
7-3	<b>UfA</b> Advance key	<b>off</b>	<b>user fail action</b>
7-4	<b>fAiL</b> Advance key	<b>off</b>	<b>input error failure</b>
7-5	<b>LodE</b> Advance key	<b>no</b>	<b>open loop detect enable</b>
7-6	<b>rP</b> Advance key	<b>off</b>	<b>ramp action</b>
7-7	<b>L.SP</b> Advance key	<b>0 degrees</b>	<b>low temperature set point(degrees)</b>
7-8	<b>h.SP</b> Advance key	<b>250 or 550</b>	<b>high temperature set point(degrees)</b>
7-9	<b>SP.Lo</b> Advance key	<b>-100.0</b>	<b>set point, low limit open loop</b>
7-10	<b>SP.Hi</b> Advance key	<b>100.0</b>	<b>set point, high limit open loop</b>

**Step 8:** Pressing the **advance key** after parameter **SP.hi** will return you to the parameter **h.Ag**. Press the **infinity key** once to return to the setup menu.

**Step 9:** Use the **up or down** keys to select the output submenu. **otPt** will be in the upper display, and **SEt** will be in lower display. Press the **Advance key** to enter the submenu.

	<u>Parameter</u>	<u>Value</u>	<u>Description</u>
	(use the <b>up or down</b> key to change parameter values)		
9-1	<b>Fn</b> Advance key	<b>heat</b>	<b>Function</b>
9-2	<b>o.tb</b> Advance key	<b>20.0</b>	<b>time base</b>
9-3	<b>O.LO</b> Advance key	<b>0%</b>	<b>low power scale</b>
9-4	<b>o.h1</b> Advance key	<b>100%</b>	<b>high power scale</b>

**Step 10:** Pressing the **advance key** after parameter **o.h1** will return you to parameter **Fn**. Press the **infinity key** to return to the output submenu.

**Step 11:** Use the **up or down** keys to select the global submenu **gLbL** will be in the upper display and **SEt** will be in the lower display. Press the **advance key** to enter the global menu.

	<u>Parameter</u>	<u>Value</u>	<u>Description</u>
11-1	<b>C_F</b> Advance key	<b>F</b>	<b>display units</b>
11-2	<b>AC.LF</b> Advance key	<b>60</b>	<b>AC line frequency</b>

**Step 12:** After pressing the **advance key** at parameter **AC.LF** will advance you back to parameter **C\_F**. Press the **infinity key** once to return to the global submenu.

**Step 13:** Use the **up or down** keys to select the communication submenu. **Cor7** will be in the upper display and **SEt** will be in the lower display. Press the **advance key** to enter the communications submenu.

	<u>Parameter</u>	<u>Value</u>	<u>Description</u>
13-1	<b>Ad.5</b> Advance key	<b>1</b>	<b>Address Standard Bus</b>

**Step 14:** Pressing the **advance key** on parameter **Ad.5** will advance you back to the same parameter, **ie.** you will still see parameter **Ad.5** displayed. Press the **infinity key** once to return to the communications sub menu.

**Step 15:** Press the **infinity key** to return to the Home page.

**Step 16:** From the Home page, press both the **up and down** keys for (3) seconds, **Ai** will appear in the upper display and **oPEr** will appear in the lower display.

### Operations Page

**Step 17:** Once **Fli** is in the upper display and **oPEr** is in the lower display, you are at the Operations menu. If not, press the **infinity key** to return to the Home menu and redo step 16.

**Step 18:** Press the **up and down** keys until **Loop** is in the upper display and **oPEr** is in the lower display. Press the **advance key** to enter the **Loop** sub menu.

	<u>Parameter</u>	<u>Value</u>	<u>Description</u>
	<b>(use the up or down keys to change values)</b>		
18-1	<b>C.r7</b> Advance key	<b>auto</b>	<b>control mode</b>
18-2	<b>C.SP</b> Advance key	<b>75</b>	<b>closed loop setpoint</b>

	<u>Parameter</u>	<u>Value</u>	<u>Description</u>
18-3	<b>id.5</b> Advance key	75 degree F.	Idle set point
18-4	<b>h.hy</b> Advance key	3.0 degree F.	Heat hysteresis reads 3 on display
18-5	<b>o.SP</b> Advance key	0.0%	Open loop set point

**Step 19:** Pressing the **advance key** at parameter **o.SP** will advance you back to parameter **C.r7**. Press the **infinity key** once to return you to operations Loop menu. Press the **infinity key** again to return you to the Home Page.

**Step 20:** Enter the Factory Page by pressing the **advance key** and **infinity keys** together and holding them for six (6) seconds. **CUSr** will be in the upper display and **FCty** will be in the lower display.

### Factory Page

**Step 21:** Once **CUSr** is in the upper display and **FCty** is in the lower display, you are in the Factory menu. If not, press the **infinity key** to return to the Home Page and redo step 20.

**Step 22:** Press the advance key if **CUSr** is in the upper display and **FCty** is in the lower display. The upper display will now read **1** and the lower display will read **CUSr**. Press the **advance key** again.

**Step 23:** The upper display will read **AC.Pu** and the lower display will read **PAr**. If the upper display does not read this way, use the **up and down** keys to change the value. Once the value has been changed, press the **infinity key** once.

**Step 24:** The upper display will read **1** and the lower display will read **CUSr**. Use the **up or down** keys to change the upper display to read **2**, press the **advance key**.

**Step 25:** The upper display will read **AC.SP** and the lower display will read **PAr**. If the upper display reads differently, use the **up or down** keys to change it to **AC.SP**. Once complete, press the **infinity key** once.

**Step 26:** The upper display will read **2** and the lower display will read **CUSr**. Use the **up or down** keys to change the upper display to read **3**. Press the **advance key** once.

**Step 27:** The upper display will read some parameter or other, and the lower display will read **PAr**. Use the **up or down** keys to change the upper display to read **none**.

Once complete, press the **infinity key**.

**Step 28:** Repeat steps 26 and 27 for display values of 4 through 20, changing each parameter to **nonE**.

**Note:** *The upper display will show the previous value you changed. You must increment this value from 4 through 20!*

**Step 29:** When all 20 parameters are set, press the **infinity key** once to return you to the main Factory Page, **CUS** will be in the upper display and **FC** will be in the lower display.

**Step 30:** Use the **up or down** keys to move to the Lockout submenu. **LoC** will be in the upper display and **FC** will be in the lower display. Press the **advance key** to enter the Lockout submenu.

	<u>Parameter</u>	<u>Value</u>	<u>Description</u>
	<b>(use the up or down keys to change parameter values)</b>		
30-1	<b>LoC.o</b>	<b>2</b>	<b>Lock Operations Page</b>
	<b>Advance key</b>		
30-2	<b>rLoC</b>	<b>1</b>	<b>Read Lockout Security</b>
	<b>Advance key</b>		
30-3	<b>SLoC</b>	<b>1</b>	<b>Set Lockout Security</b>
	<b>Advance key</b>		

**Step 31:** Pressing the **advance key** at parameter **SLoC** will advance you to back to parameter **LoC.o**. Press the **infinity key** to return you to the Lockout submenu.

**Step 32:** Press the **infinity key** again to return you to the Home page.

**Congratulations! Programming is Complete.**



# SCHEMATICS

---

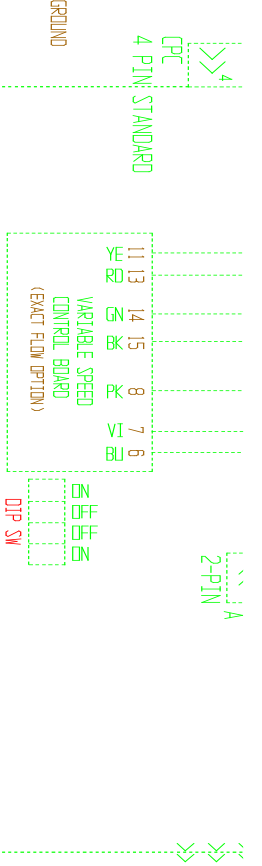
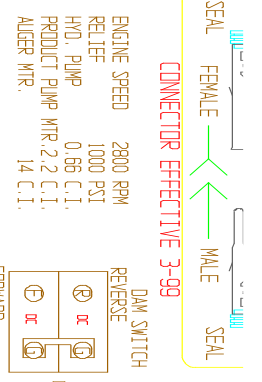

		PROJECT:	12VDC FUEL OIL
		ASS'Y:	BURNER VERT
STEPP MFG CO INC NORTH BRANCH, MN. 55056		PART NAME:	WIRING
INV NO:		FILE NAME:	12VVOBBW-EZ
MAT'L: AS NOTED		WT:	QTY: 1
JOB NO:			

NOTE: ASSED AS OF 5



SHOP NOTES		MACHINE CODE		ROUTING:		PROJECT:	
STANDARD SHOP TOLERANCE		LOCK FORMER:		CAGE CODE: 06447		KABOTA 482 DIESEL ENGI	
UNLESS OTHERWISE NOTED:		WIEDEMANN:		DWN: 6703		ENGINE COVER HARNESS	
±1/16" & ±1°		LARGE BRAKE:		DWN BY: SGS		PART NAME: FINAL DETAIL	
				REV:		FILE NAME: K482-MSL1	
				INV NO:		INV AMT EA:	
				MAT'L:		JOB NO:	
				AS NOTED		JOB QTY	



STEP PEG CO. INC.  
NORTH BRANCH, MN. 55056

NOT TO BE REPRODUCED  
IN ANY FORM WITHOUT THE  
EXPRESSED WRITTEN PERMISSION  
OF STEP PEG CO. INC.



# HEAT TRANSFER OIL MSDS

---

# MATERIAL SAFETY DATA SHEET

## SECTION 1

## PRODUCT AND COMPANY IDENTIFICATION

### PRODUCT

**Product Name:** EXXON TERESSTIC 100

**Product Description:** Base Oil and Additives

**Product Code:** 16013

**Intended Use:** Circulating oil

### COMPANY IDENTIFICATION

**Supplier:** Canada Imperial Oil Limited, An Affiliate of Exxon Mobil Corporation

P.O. Box 2480, Station M

Calgary, ALBERTA. T2P 3M9 Canada

**24 Hour Health Emergency** 519-339-2145

**Transportation Emergency Phone** 519-339-2145

**Supplier General Contact** 1-800-567-3776

## SECTION 2

## COMPOSITION / INFORMATION ON INGREDIENTS

No Reportable Hazardous Substance(s) or Complex Substance(s).

## SECTION 3

## HAZARDS IDENTIFICATION

This material is not considered to be hazardous according to regulatory guidelines (see (M)SDS Section 15).

### POTENTIAL HEALTH EFFECTS

Low order of toxicity. Excessive exposure may result in eye, skin, or respiratory irritation.

**NFPA Hazard ID:** Health: 0 Flammability: 1 Reactivity: 0

**HMIS Hazard ID:** Health: 0 Flammability: 1 Reactivity: 0

**NOTE:** This material should not be used for any other purpose than the intended use in Section 1 without expert advice. Health studies have shown that chemical exposure may cause potential human health risks which may vary from person to person.

## SECTION 4

## FIRST AID MEASURES

### INHALATION

Remove from further exposure. For those providing assistance, avoid exposure to yourself or others. Use adequate respiratory protection. If respiratory irritation, dizziness, nausea, or unconsciousness occurs, seek immediate medical assistance. If breathing has stopped, assist ventilation with a mechanical device or use mouth-to-mouth resuscitation.

### SKIN CONTACT

Wash contact areas with soap and water.

#### EYE CONTACT

Flush thoroughly with water. If irritation occurs, get medical assistance.

#### INGESTION

First aid is normally not required. Seek medical attention if discomfort occurs.

<b>SECTION 5</b>
------------------

<b>FIRE FIGHTING MEASURES</b>
-------------------------------

#### EXTINGUISHING MEDIA

**Appropriate Extinguishing Media:** Use water fog, foam, dry chemical or carbon dioxide (CO<sub>2</sub>) to extinguish flames.

**Inappropriate Extinguishing Media:** Straight Streams of Water

#### FIRE FIGHTING

**Fire Fighting Instructions:** Evacuate area. Prevent runoff from fire control or dilution from entering streams, sewers, or drinking water supply. Firefighters should use standard protective equipment and in enclosed spaces, self-contained breathing apparatus (SCBA). Use water spray to cool fire exposed surfaces and to protect personnel.

**Hazardous Combustion Products:** Sulfur oxides, Aldehydes, Smoke, Fume, Oxides of carbon, Incomplete combustion products

#### FLAMMABILITY PROPERTIES

**Flash Point [Method]:** 220C (428F) [ ASTM D-92]

**Flammable Limits (Approximate volume % in air):** LEL: 0.9 UEL: 7.0

**Autoignition Temperature:** 330°C (626°F)

<b>SECTION 6</b>
------------------

<b>ACCIDENTAL RELEASE MEASURES</b>
------------------------------------

#### NOTIFICATION PROCEDURES

In the event of a spill or accidental release, notify relevant authorities in accordance with all applicable regulations. In the event of a spill or accidental release, notify relevant authorities in accordance with all applicable regulations. US regulations require reporting releases of this material to the environment which exceed the applicable reportable quantity or oil spills which could reach any waterway including intermittent dry creeks. The National Response Center can be reached at (800)424-8802.

#### SPILL MANAGEMENT

**Land Spill:** Stop leak if you can do it without risk. Recover by pumping or with suitable absorbent.

**Water Spill:** Stop leak if you can do it without risk. Confine the spill immediately with booms. Warn other shipping. Remove from the surface by skimming or with suitable absorbents. Seek the advice of a specialist before using dispersants.

Water spill and land spill recommendations are based on the most likely spill scenario for this material;

however, geographic conditions, wind, temperature, (and in the case of a water spill) wave and current direction and speed may greatly influence the appropriate action to be taken. For this reason, local experts should be consulted. Note: Local regulations may prescribe or limit action to be taken.

## ENVIRONMENTAL PRECAUTIONS

Large Spills: Dike far ahead of liquid spill for later recovery and disposal. Prevent entry into waterways, sewers, basements or confined areas.

<b>SECTION 7</b>	<b>HANDLING AND STORAGE</b>
------------------	-----------------------------

### HANDLING

Prevent small spills and leakage to avoid slip hazard.

**Static Accumulator:** This material is a static accumulator.

### STORAGE

Do not store in open or unlabelled containers.

<b>SECTION 8</b>	<b>EXPOSURE CONTROLS / PERSONAL PROTECTION</b>
------------------	--

**Exposure limits/standards for materials that can be formed when handling this product:** When mists / aerosols can occur, the following are recommended: 5 mg/m<sup>3</sup> - ACGIH TLV, 10 mg/m<sup>3</sup> - ACGIH STEL, 5 mg/m<sup>3</sup> - OSHA PEL.

NOTE: Limits/standards shown for guidance only. Follow applicable regulations.

### ENGINEERING CONTROLS

The level of protection and types of controls necessary will vary depending upon potential exposure conditions. Control measures to consider:

No special requirements under ordinary conditions of use and with adequate ventilation.

### PERSONAL PROTECTION

Personal protective equipment selections vary based on potential exposure conditions such as applications, handling practices, concentration and ventilation. Information on the selection of protective equipment for use with this material, as provided below, is based upon intended, normal usage.

**Respiratory Protection:** If engineering controls do not maintain airborne contaminant concentrations at a level which is adequate to protect worker health, an approved respirator may be appropriate. Respirator selection, use, and maintenance must be in accordance with regulatory requirements, if applicable. Types of respirators to be considered for this material include:

No special requirements under ordinary conditions of use and with adequate ventilation.

For high airborne concentrations, use an approved supplied-air respirator, operated in positive pressure mode. Supplied air respirators with an escape bottle may be appropriate when oxygen levels are inadequate, gas/vapor warning properties are poor, or if air purifying filter capacity/rating may be exceeded.

**Hand Protection:** Any specific glove information provided is based on published literature and glove manufacturer data. Work conditions can greatly affect glove durability; inspect and replace worn or damaged gloves. The types of gloves to be considered for this material include:

No protection is ordinarily required under normal conditions of use.

**Eye Protection:** If contact is likely, safety glasses with side shields are recommended.

**Skin and Body Protection:** Any specific clothing information provided is based on published literature or manufacturer data. The types of clothing to be considered for this material include:

No skin protection is ordinarily required under normal conditions of use. In accordance with good industrial hygiene practices, precautions should be taken to avoid skin contact.

**Specific Hygiene Measures:** Always observe good personal hygiene measures, such as washing after handling the material and before eating, drinking, and/or smoking. Routinely wash work clothing and protective equipment to remove contaminants. Discard contaminated clothing and footwear that cannot be cleaned. Practice good house-keeping.

## ENVIRONMENTAL CONTROLS

See Sections 6, 7, 12, 13.

<b>SECTION 9</b>	<b>PHYSICAL AND CHEMICAL PROPERTIES</b>
------------------	---

Typical physical and chemical properties are given below. Consult the Supplier in Section 1 for additional data.

### GENERAL INFORMATION

**Physical State:** Liquid

**Color:** Yellow

**Odor:** Characteristic

**Odor Threshold:** N/D

### IMPORTANT HEALTH, SAFETY, AND ENVIRONMENTAL INFORMATION

**Relative Density (at 15 C):** 0.83

**Flash Point [Method]:** 220C (428F) [ASTM D-92]

**Flammable Limits (Approximate volume % in air):** LEL: 0.9 UEL: 7.0

**Autoignition Temperature:** 330°C (626°F)

**Boiling Point / Range:** N/D

**Vapor Density (Air = 1):** N/D

**Vapor Pressure:** [N/D at 20 °C] | < 1 kPa (7.5 mm Hg) at 38C

**Evaporation Rate (n-butyl acetate = 1):** < 1

**pH:** N/A

**Log Pow (n-Octanol/Water Partition Coefficient):** > 3.5

**Solubility in Water:** Negligible

**Viscosity:** 100 cSt (100 mm<sup>2</sup>/sec) at 40 C

**Oxidizing Properties:** See Sections 3, 15, 16.

### OTHER INFORMATION

**Freezing Point:** N/D

**Melting Point:** N/A

**Pour Point:** -12°C (10°F)

**DMSO Extract (mineral oil only), IP-346:** < 3 %wt

<b>SECTION 10</b>	<b>STABILITY AND REACTIVITY</b>
-------------------	---------------------------------

**STABILITY:** Material is stable under normal conditions.

**CONDITIONS TO AVOID:** Excessive heat. High energy sources of ignition.

**MATERIALS TO AVOID:** Strong oxidizers

**HAZARDOUS DECOMPOSITION PRODUCTS:** Material does not decompose at ambient temperatures.

**HAZARDOUS POLYMERIZATION:** Will not occur.

<b>SECTION 11</b>	<b>TOXICOLOGICAL INFORMATION</b>
-------------------	----------------------------------

**ACUTE TOXICITY**

<u>Route of Exposure</u>	<u>Conclusion / Remarks</u>
<b>Inhalation</b>	
Toxicity (Rat): LC50 > 5000 mg/m3	Minimally Toxic. Based on test data for structurally similar materials.
Irritation: No end point data.	Negligible hazard at ambient/normal handling temperatures. Based on assessment of the components.
<b>Ingestion</b>	
Toxicity (Rat): LD50 > 2000 mg/kg	Minimally Toxic. Based on test data for structurally similar materials.
<b>Skin</b>	
Toxicity (Rabbit): LD50 > 2000 mg/kg	Minimally Toxic. Based on test data for structurally similar materials.
Irritation (Rabbit): Data available.	Negligible irritation to skin at ambient temperatures. Based on test data for structurally similar materials.
<b>Eye</b>	
Irritation (Rabbit): Data available.	May cause mild, short-lasting discomfort to eyes. Based on test data for structurally similar materials.

**CHRONIC/OTHER EFFECTS**

**Contains:**

Base oil severely refined: Not carcinogenic in animal studies. Representative material passes IP-346, Modified Ames test, and/or other screening tests. Dermal and inhalation studies showed minimal effects; lung non-specific infiltration of immune cells, oil deposition and minimal granuloma formation. Not sensitizing in test animals.

Additional information is available by request.

**The following ingredients are cited on the lists below:** None.

--REGULATORY LISTS SEARCHED--

1 = NTP CARC

3 = IARC 1

5 = IARC 2B

2 = NTP SUS

4 = IARC 2A

6 = OSHA CARC



**SECTION 12****ECOLOGICAL INFORMATION**

The information given is based on data available for the material, the components of the material, and similar materials.

**ECOTOXICITY**

Material -- Not expected to be harmful to aquatic organisms.

**MOBILITY**

Base oil component -- Low solubility and floats and is expected to migrate from water to the land. Expected to partition to sediment and wastewater solids.

**PERSISTENCE AND DEGRADABILITY****Biodegradation:**

Base oil component -- Expected to be inherently biodegradable

**BIOACCUMULATION POTENTIAL**

Base oil component -- Has the potential to bioaccumulate, however metabolism or physical properties may reduce the bioconcentration or limit bioavailability.

**SECTION 13****DISPOSAL CONSIDERATIONS**

Disposal recommendations based on material as supplied. Disposal must be in accordance with current applicable laws and regulations, and material characteristics at time of disposal.

**DISPOSAL RECOMMENDATIONS**

Product is suitable for burning in an enclosed controlled burner for fuel value or disposal by supervised incineration at very high temperatures to prevent formation of undesirable combustion products.

**REGULATORY DISPOSAL INFORMATION**

RCRA Information: The unused product, in our opinion, is not specifically listed by the EPA as a hazardous waste (40 CFR, Part 261D), nor is it formulated to contain materials which are listed as hazardous wastes. It does not exhibit the hazardous characteristics of ignitability, corrosivity or reactivity and is not formulated with contaminants as determined by the Toxicity Characteristic Leaching Procedure (TCLP). However, used product may be regulated.

**Empty Container Warning** Empty Container Warning (where applicable): Empty containers may contain residue and can be dangerous. Do not attempt to refill or clean containers without proper instructions. Empty drums should be completely drained and safely stored until appropriately reconditioned or disposed. Empty containers should be taken for recycling, recovery, or disposal through suitably qualified or licensed contractor and in accordance with governmental regulations. DO NOT PRESSURISE, CUT, WELD, BRAZE, SOLDER, DRILL, GRIND, OR EXPOSE SUCH CONTAINERS TO HEAT, FLAME, SPARKS, STATIC ELECTRICITY, OR OTHER SOURCES OF IGNITION. THEY MAY EXPLODE AND CAUSE INJURY OR DEATH.

<b>SECTION 14</b>	<b>TRANSPORT INFORMATION</b>
-------------------	------------------------------

**LAND (DOT) :** Not Regulated for Land Transport

**LAND (TDG) :** Not Regulated for Land Transport

**SEA (IMDG) :** Not Regulated for Sea Transport according to IMDG-Code

**AIR (IATA) :** Not Regulated for Air Transport

<b>SECTION 15</b>	<b>REGULATORY INFORMATION</b>
-------------------	-------------------------------

**OSHA HAZARD COMMUNICATION STANDARD:** When used for its intended purposes, this material is not classified as hazardous in accordance with OSHA 29 CFR 1910.1200.

**NATIONAL CHEMICAL INVENTORY LISTING:** DSL, TSCA

**EPCRA:** This material contains no extremely hazardous substances.

**SARA (311/312) REPORTABLE HAZARD CATEGORIES:** None.

**SARA (313) TOXIC RELEASE INVENTORY:** This material contains no chemicals subject to the supplier notification requirements of the SARA 313 Toxic Release Program.

**The Following Ingredients are Cited on the Lists Below:**

Chemical Name	CAS Number	List Citations
DIPHENYLAMINE	122-39-4	5, 9
XYLENES	1330-20-7	5, 9

--REGULATORY LISTS SEARCHED--

- |               |                  |                   |             |
|---------------|------------------|-------------------|-------------|
| 1 = ACGIH ALL | 6 = TSCA 5a2     | 11 = CA P65 REPRO | 16 = MN RTK |
| 2 = ACGIH A1  | 7 = TSCA 5e      | 12 = CA RTK       | 17 = NJ RTK |
| 3 = ACGIH A2  | 8 = TSCA 6       | 13 = IL RTK       | 18 = PA RTK |
| 4 = OSHA Z    | 9 = TSCA 12b     | 14 = LA RTK       | 19 = RI RTK |
| 5 = TSCA 4    | 10 = CA P65 CARC | 15 = MI 293       |             |

Code key: CARC=Carcinogen; REPRO=Reproductive

<b>SECTION 16</b>	<b>OTHER INFORMATION</b>
-------------------	--------------------------

N/D = Not determined, N/A = Not applicable

**THIS SAFETY DATA SHEET CONTAINS THE FOLLOWING REVISIONS:**

- Revision Changes:  
 Section 13: Empty Container Warning was modified.  
 Section 08: Hand Protection was modified.  
 Section 01: Company Mailing Address was modified.  
 Section 15: List Citation Table - Header was modified.  
 Section 06: Notification Procedures was modified.  
 Section 15: TSCA Class 2 Statement was deleted.

The information and recommendations contained herein are, to the best of ExxonMobil's knowledge and belief, accurate and reliable as of the date issued. You can contact ExxonMobil to insure that this document is the most current available from ExxonMobil. The information and recommendations are offered for the user's consideration and examination. It is the user's responsibility to satisfy itself that the product is suitable for the intended use. If buyer repackages this product, it is the user's responsibility to insure proper health, safety and other necessary information is included with and/or on the container. Appropriate warnings and safe-handling procedures should be provided to handlers and users. Alteration of this document is strictly prohibited. Except to the extent required by law, re-publication or retransmission of this document, in whole or in part, is not permitted. The term, "ExxonMobil" is used for convenience, and may include any one or more of ExxonMobil Chemical Company, Exxon Mobil Corporation, or any affiliates in which they directly or indirectly hold any interest.

---

Internal Use Only

MHC: 0, 0, 0, 0, 0, 0

PPEC: A

DGN: 5014320 (1012313)

---

Copyright 2002 Exxon Mobil Corporation, All rights reserved

Copyright 2002 Exxon Mobil Corporation, All rights reserved



# HYDRAULIC OIL MSDS

---

# MATERIAL SAFETY DATA SHEET

<b>SECTION 1</b>	<b>PRODUCT AND COMPANY IDENTIFICATION</b>
------------------	---

## PRODUCT

**Product Name:** UNIVIS N 32  
**Product Description:** Base Oil and Additives  
**Product Code:** 8259  
**Intended Use:** Hydraulic fluid

## COMPANY IDENTIFICATION

**Supplier:** Canada Imperial Oil Limited, An Affiliate of Exxon Mobil Corporation  
P.O. Box 4029, Station A  
Calgary, ALBERTA. T2P 3M9 Canada

**24 Hour Health Emergency** 519-339-2145  
**Transportation Emergency Phone** 519-339-2145  
**Supplier General Contact** 1-800-567-3776

<b>SECTION 2</b>	<b>COMPOSITION / INFORMATION ON INGREDIENTS</b>
------------------	---

## Reportable Hazardous Substance(s) or Complex Substance(s)

Name	CAS#	Concentration*
HYDROTREATED LIGHT NAPHTHENIC DISTILLATE (PETROLEUM)	64742-53-6	20 - 30%

\* All concentrations are percent by weight unless material is a gas. Gas concentrations are in percent by volume.

<b>SECTION 3</b>	<b>HAZARDS IDENTIFICATION</b>
------------------	-------------------------------

This material is not considered to be hazardous according to regulatory guidelines (see (M)SDS Section 15).

## POTENTIAL HEALTH EFFECTS

Low order of toxicity. Excessive exposure may result in eye, skin, or respiratory irritation. High-pressure injection under skin may cause serious damage.

**NFPA Hazard ID:** Health: 0 Flammability: 1 Reactivity: 0  
**HMIS Hazard ID:** Health: 0 Flammability: 1 Reactivity: 0

**NOTE:** This material should not be used for any other purpose than the intended use in Section 1 without expert advice. Health studies have shown that chemical exposure may cause potential human health risks which may vary from person to person.

<b>SECTION 4</b>	<b>FIRST AID MEASURES</b>
------------------	---------------------------

**INHALATION**

Remove from further exposure. For those providing assistance, avoid exposure to yourself or others. Use adequate respiratory protection. If respiratory irritation, dizziness, nausea, or unconsciousness occurs, seek immediate medical assistance. If breathing has stopped, assist ventilation with a mechanical device or use mouth-to-mouth resuscitation.

**SKIN CONTACT**

Wash contact areas with soap and water. If product is injected into or under the skin, or into any part of the body, regardless of the appearance of the wound or its size, the individual should be evaluated immediately by a physician as a surgical emergency. Even though initial symptoms from high pressure injection may be minimal or absent, early surgical treatment within the first few hours may significantly reduce the ultimate extent of injury.

**EYE CONTACT**

Flush thoroughly with water. If irritation occurs, get medical assistance.

**INGESTION**

First aid is normally not required. Seek medical attention if discomfort occurs.

<b>SECTION 5</b>	<b>FIRE FIGHTING MEASURES</b>
------------------	-------------------------------

**EXTINGUISHING MEDIA**

**Appropriate Extinguishing Media:** Use water fog, foam, dry chemical or carbon dioxide (CO<sub>2</sub>) to extinguish flames.

**Inappropriate Extinguishing Media:** Straight Streams of Water

**FIRE FIGHTING**

**Fire Fighting Instructions:** Evacuate area. Prevent runoff from fire control or dilution from entering streams, sewers, or drinking water supply. Firefighters should use standard protective equipment and in enclosed spaces, self-contained breathing apparatus (SCBA). Use water spray to cool fire exposed surfaces and to protect personnel.

**Unusual Fire Hazards:** Pressurized mists may form a flammable mixture.

**Hazardous Combustion Products:** Smoke, Fume, Sulfur oxides, Aldehydes, Oxides of carbon, Incomplete combustion products

**FLAMMABILITY PROPERTIES**

**Flash Point [Method]:** 165C (329F) [ASTM D-93]

**Flammable Limits (Approximate volume % in air):** LEL: 0.9 UEL: 7.0

**Autoignition Temperature:** N/D

**SECTION 6****ACCIDENTAL RELEASE MEASURES****NOTIFICATION PROCEDURES**

In the event of a spill or accidental release, notify relevant authorities in accordance with all applicable regulations. U.S. regulations require reporting releases of this material to the environment which exceed the reportable quantity or oil spills which could reach any waterway including intermittent dry creeks. The National Response Center can be reached at (800)424-8802.

**SPILL MANAGEMENT**

**Land Spill:** Stop leak if you can do it without risk. Recover by pumping or with suitable absorbent.

**Water Spill:** Stop leak if you can do it without risk. Confine the spill immediately with booms. Warn other shipping. Remove from the surface by skimming or with suitable absorbents. Seek the advice of a specialist before using dispersants.

Water spill and land spill recommendations are based on the most likely spill scenario for this material; however, geographic conditions, wind, temperature, (and in the case of a water spill) wave and current direction and speed may greatly influence the appropriate action to be taken. For this reason, local experts should be consulted. Note: Local regulations may prescribe or limit action to be taken.

**ENVIRONMENTAL PRECAUTIONS**

Large Spills: Dike far ahead of liquid spill for later recovery and disposal. Prevent entry into waterways, sewers, basements or confined areas.

**SECTION 7****HANDLING AND STORAGE****HANDLING**

Prevent small spills and leakage to avoid slip hazard.

**Static Accumulator:** This material is a static accumulator.

**STORAGE**

Do not store in open or unlabelled containers.

**SECTION 8****EXPOSURE CONTROLS / PERSONAL PROTECTION**

**Exposure limits/standards for materials that can be formed when handling this product:** When mists / aerosols can occur, the following are recommended: 5 mg/m<sup>3</sup> - ACGIH TLV, 10 mg/m<sup>3</sup> - ACGIH STEL, 5 mg/m<sup>3</sup> - OSHA PEL.

NOTE: Limits/standards shown for guidance only. Follow applicable regulations.

**ENGINEERING CONTROLS**

The level of protection and types of controls necessary will vary depending upon potential exposure conditions. Control measures to consider:

No special requirements under ordinary conditions of use and with adequate ventilation.



## PERSONAL PROTECTION

Personal protective equipment selections vary based on potential exposure conditions such as applications, handling practices, concentration and ventilation. Information on the selection of protective equipment for use with this material, as provided below, is based upon intended, normal usage.

**Respiratory Protection:** If engineering controls do not maintain airborne contaminant concentrations at a level which is adequate to protect worker health, an approved respirator may be appropriate. Respirator selection, use, and maintenance must be in accordance with regulatory requirements, if applicable. Types of respirators to be considered for this material include:

No special requirements under ordinary conditions of use and with adequate ventilation. For high airborne concentrations, use an approved supplied-air respirator, operated in positive pressure mode. Supplied air respirators with an escape bottle may be appropriate when oxygen levels are inadequate, gas/vapor warning properties are poor, or if air purifying filter capacity/rating may be exceeded.

**Hand Protection:** Any specific glove information provided is based on published literature and glove manufacturer data. Work conditions can greatly effect glove durability; inspect and replace worn or damaged gloves. The types of gloves to be considered for this material include:

No protection is ordinarily required under normal conditions of use.

**Eye Protection:** If contact is likely, safety glasses with side shields are recommended.

**Skin and Body Protection:** Any specific clothing information provided is based on published literature or manufacturer data. The types of clothing to be considered for this material include:

No skin protection is ordinarily required under normal conditions of use. In accordance with good industrial hygiene practices, precautions should be taken to avoid skin contact.

**Specific Hygiene Measures:** Always observe good personal hygiene measures, such as washing after handling the material and before eating, drinking, and/or smoking. Routinely wash work clothing and protective equipment to remove contaminants. Discard contaminated clothing and footwear that cannot be cleaned. Practice good housekeeping.

## ENVIRONMENTAL CONTROLS

See Sections 6, 7, 12, 13.

<b>SECTION 9</b>	<b>PHYSICAL AND CHEMICAL PROPERTIES</b>
------------------	---

Typical physical and chemical properties are given below. Consult the Supplier in Section 1 for additional data.

## GENERAL INFORMATION

**Physical State:** Liquid  
**Color:** Yellow  
**Odor:** Characteristic  
**Odor Threshold:** N/D

## IMPORTANT HEALTH, SAFETY, AND ENVIRONMENTAL INFORMATION

**Relative Density (at 15 C):** 0.87  
**Flash Point [Method]:** 165C (329F) [ ASTM D-93]  
**Flammable Limits (Approximate volume % in air):** LEL: 0.9 UEL: 7.0  
**Autoignition Temperature:** N/D  
**Boiling Point / Range:** 229C (444F) - 512C (954F)  
**Vapor Density (Air = 1):** N/D  
**Vapor Pressure:** [N/D at 40 °C ] | < 1 kPa (7.5 mm Hg) at 38C  
**Evaporation Rate (n-butyl acetate = 1):** < 0.1  
**pH:** N/A  
**Log Pow (n-Octanol/Water Partition Coefficient):** > 3.5  
**Solubility in Water:** Negligible  
**Viscosity:** 32 cSt (32 mm<sup>2</sup>/sec ) at 40 C  
**Oxidizing Properties:** See Sections 3, 15, 16.

**OTHER INFORMATION****Freezing Point:** N/D**Melting Point:** N/A**Pour Point:** -48°C (-54°F)**DMSO Extract (mineral oil only), IP-346:** < 3 %wt

<b>SECTION 10</b>	<b>STABILITY AND REACTIVITY</b>
-------------------	---------------------------------

**STABILITY:** Material is stable under normal conditions.**CONDITIONS TO AVOID:** Excessive heat. High energy sources of ignition.**MATERIALS TO AVOID:** Strong oxidizers**HAZARDOUS DECOMPOSITION PRODUCTS:** Material does not decompose at ambient temperatures.**HAZARDOUS POLYMERIZATION:** Will not occur.

<b>SECTION 11</b>	<b>TOXICOLOGICAL INFORMATION</b>
-------------------	----------------------------------

**ACUTE TOXICITY**

<u>Route of Exposure</u>	<u>Conclusion / Remarks</u>
<b>Inhalation</b>	
Toxicity (Rat): LC50 > 5000 mg/m <sup>3</sup>	Minimally Toxic. Based on assessment of the components.
Irritation: No end point data.	Negligible hazard at ambient/normal handling temperatures. Based on assessment of the components.
<b>Ingestion</b>	
Toxicity (Rat): LD50 > 2000 mg/kg	Minimally Toxic. Based on test data for structurally similar materials.
<b>Skin</b>	
Toxicity (Rabbit): LD50 > 2000 mg/kg	Minimally Toxic. Based on test data for structurally similar materials.
Irritation (Rabbit): Data available.	Negligible irritation to skin at ambient temperatures. Based on assessment of the components.
<b>Eye</b>	
Irritation (Rabbit): Data available.	May cause mild, short-lasting discomfort to eyes. Based on assessment of the components.

**CHRONIC/OTHER EFFECTS****Contains:**

Base oil severely refined: Not carcinogenic in animal studies. Representative material passes IP-346, Modified Ames test, and/or other screening tests. Dermal and inhalation studies showed minimal effects; lung non-specific infiltration of immune cells, oil deposition and minimal granuloma formation. Not sensitizing in test animals.

Additional information is available by request.

**The following ingredients are cited on the lists below:** None.

--REGULATORY LISTS SEARCHED--

1 = NTP CARC

3 = IARC 1

5 = IARC 2B

2 = NTP SUS

4 = IARC 2A

6 = OSHA CARC

**SECTION 12****ECOLOGICAL INFORMATION**

The information given is based on data available for the material, the components of the material, and similar materials.

**ECOTOXICITY**

Material -- Not expected to be harmful to aquatic organisms.

**MOBILITY**

Base oil component -- Low solubility and floats and is expected to migrate from water to the land. Expected to partition to sediment and wastewater solids.

**PERSISTENCE AND DEGRADABILITY****Biodegradation:**

Base oil component -- Expected to be inherently biodegradable

**BIOACCUMULATION POTENTIAL**

Base oil component -- Has the potential to bioaccumulate, however metabolism or physical properties may reduce the bioconcentration or limit bioavailability.

**SECTION 13****DISPOSAL CONSIDERATIONS**

Disposal recommendations based on material as supplied. Disposal must be in accordance with current applicable laws and regulations, and material characteristics at time of disposal.

**DISPOSAL RECOMMENDATIONS**

Product is suitable for burning in an enclosed controlled burner for fuel value or disposal by supervised incineration at very high temperatures to prevent formation of undesirable combustion products.

**REGULATORY DISPOSAL INFORMATION**

RCRA Information: The unused product, in our opinion, is not specifically listed by the EPA as a hazardous waste (40 CFR, Part 261D), nor is it formulated to contain materials which are listed as hazardous wastes. It does not exhibit the hazardous characteristics of ignitability, corrosivity or reactivity and is not formulated with contaminants as determined by the Toxicity Characteristic Leaching Procedure (TCLP). However, used product may be regulated.

**Empty Container Warning** PRECAUTIONARY LABEL TEXT: Empty containers may retain residue and can be dangerous. DO NOT PRESSURIZE, CUT, WELD, BRAZE, SOLDER, DRILL, GRIND OR EXPOSE SUCH CONTAINERS TO HEAT, FLAME, SPARKS, STATIC ELECTRICITY, OR OTHER SOURCES OF IGNITION; THEY MAY EXPLODE AND CAUSE INJURY OR DEATH. Do not attempt to refill or clean container since residue is difficult to remove. Empty drums should be completely drained, properly bunged and promptly returned to a drum reconditioner. All containers should be disposed of in an environmentally safe manner and in accordance with governmental regulations.

<b>SECTION 14</b>	<b>TRANSPORT INFORMATION</b>
-------------------	------------------------------

**LAND (DOT) :** Not Regulated for Land Transport

**LAND (TDG) :** Not Regulated for Land Transport

**SEA (IMDG) :** Not Regulated for Sea Transport according to IMDG-Code

**AIR (IATA) :** Not Regulated for Air Transport

<b>SECTION 15</b>	<b>REGULATORY INFORMATION</b>
-------------------	-------------------------------

**OSHA HAZARD COMMUNICATION STANDARD:** When used for its intended purposes, this material is not classified as hazardous in accordance with OSHA 29 CFR 1910.1200.

**NATIONAL CHEMICAL INVENTORY LISTING:** DSL, TSCA

**EPCRA:** This material contains no extremely hazardous substances.

**SARA (311/312) REPORTABLE HAZARD CATEGORIES:** Delayed Health.

**SARA (313) TOXIC RELEASE INVENTORY:** This material contains no chemicals subject to the supplier notification requirements of the SARA 313 Toxic Release Program.

**The Following Ingredients are Cited on the Lists Below:\***

Chemical Name	CAS Number	List Citations
HYDROTREATED LIGHT NAPHTHENIC DISTILLATE (PETROLEUM)	64742-53-6	13, 17, 18
PHOSPHORODITHOIC ACID, O,O-DI C1-14-ALKYL ESTERS, ZINC SALTS (2:1) (ZDDP)	68649-42-3	15

--REGULATORY LISTS SEARCHED--

- |               |                  |                   |             |
|---------------|------------------|-------------------|-------------|
| 1 = ACGIH ALL | 6 = TSCA 5a2     | 11 = CA P65 REPRO | 16 = MN RTK |
| 2 = ACGIH A1  | 7 = TSCA 5e      | 12 = CA RTK       | 17 = NJ RTK |
| 3 = ACGIH A2  | 8 = TSCA 6       | 13 = IL RTK       | 18 = PA RTK |
| 4 = OSHA Z    | 9 = TSCA 12b     | 14 = LA RTK       | 19 = RI RTK |
| 5 = TSCA 4    | 10 = CA P65 CARC | 15 = MI 293       |             |

Code key: CARC=Carcinogen; REPRO=Reproductive

\* EPA recently added new chemical substances to its TSCA Section 4 test rules. Please contact the supplier to confirm whether the ingredients in this product currently appear on a TSCA 4 or TSCA 12b list.

N/D = Not determined, N/A = Not applicable

**THIS SAFETY DATA SHEET CONTAINS THE FOLLOWING REVISIONS:**

No revision information is available.

-----  
-----  
-----

The information and recommendations contained herein are, to the best of ExxonMobil's knowledge and belief, accurate and reliable as of the date issued. You can contact ExxonMobil to insure that this document is the most current available from ExxonMobil. The information and recommendations are offered for the user's consideration and examination. It is the user's responsibility to satisfy itself that the product is suitable for the intended use. If buyer repackages this product, it is the user's responsibility to insure proper health, safety and other necessary information is included with and/or on the container. Appropriate warnings and safe-handling procedures should be provided to handlers and users. Alteration of this document is strictly prohibited. Except to the extent required by law, re-publication or retransmission of this document, in whole or in part, is not permitted. The term, "ExxonMobil" is used for convenience, and may include any one or more of ExxonMobil Chemical Company, Exxon Mobil Corporation, or any affiliates in which they directly or indirectly hold any interest.

-----  
-----

Internal Use Only

MHC: 0, 0, 0, 0, 0, 0

PPEC: A

DGN: 5007202 (1012936)

-----  
-----

Copyright 2002 Exxon Mobil Corporation, All rights reserved



# TIRE INFORMATION

---





# ENGINE MANUAL

---